

CONTROL TECHNIQUES



DIGITAX HD

MINIMUM SIZE, MAXIMUM PERFORMANCE
SERVO DRIVES

DRIVE OBSESSED

SERVO SOLUTIONS FOR CONTINUOUS & PULSE DUTY APPLICATIONS

Receive the ultimate in performance and flexibility for machinery manufacturers with a broad range of servo drives and motors.



Digitax HD

Bring superior performance to high dynamic, pulse duty applications, where high peak torque is essential for fast acceleration with the Digitax HD range.

Unidrive M700

Providing optimum performance and an extensive power range - M700 is the ideal option for continuous duty applications that need precise continuous torque delivery.

Unimotor

Unimotor is a comprehensive family of high performance AC brushless servo motors. With a wide torque and speed range and a broad selection of feedback options, Unimotor offers the perfect match for Digitax HD and Unidrive M700 to meet any application requirement.





Digitax HD

0.25 kW - 7.5 kW
(0.6 hp - 9.8 hp)
200 V | 400 V



Unidrive M700

0.75 kW - 2.8 MW
(1 hp - 4,200 hp)
200 V | 400 V | 575 V | 690 V

300% Overload

200% Overload



Pulse Duty Servo Range - Unimotor HD

(Optimized with the Control Techniques pulse duty drive)



Continuous Duty Servo Range - Unimotor FM

(Optimized with the Control Techniques continuous duty drive)



Induction



High efficiency motors

MINIMUM SIZE SERVO SOLUTIONS

0.7 Nm - 51 Nm with 153 Nm peak 1.5 A – 16 A with 48 A peak
200 V | 400 V | 0.25 kW - 7.5 kW

Downsize cost and upsize floor space.

With a tiny footprint but exceptional power density, Digitax HD is one of the smallest servo drives on the market today. Build the most compact cabinets possible.

The market's narrowest servo drive

- Digitax HD is just 40mm (1.6 in) wide
- 25 drives, up to 16A per drive, can fit in just 1 meter (40 in) of cabinet space

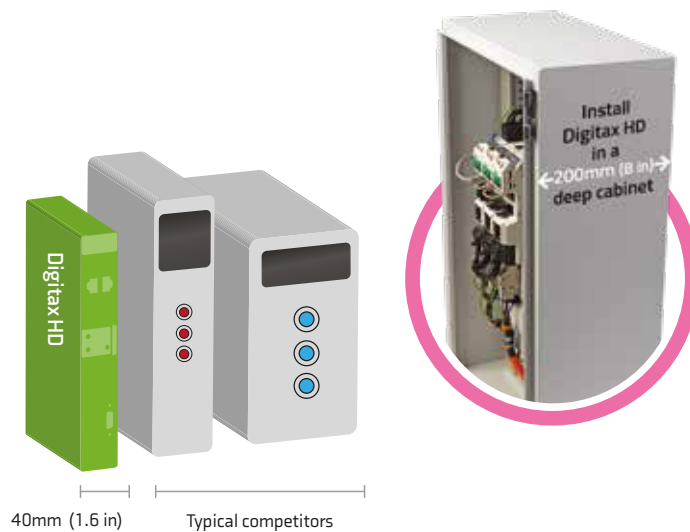

Drive dimensions

Frame size	Dimensions H x W x D mm (in)	Weight kg (lb)	Nominal current @ 400v	Peak current @ 400v
1	233 x 40 x 174 (9.17 x 1.57 x 6.85)	0.75 (1.65)	4.2 A	12.6A
2	278 x 40 x 174 (11.0 x 1.57 x 6.85)	1.3 (3.0)	10.5A	31.5A
3	328 x 40 x 174 (12.9 x 1.57 x 6.85)	1.5 (3.3)	12.9A	48A



ULTRAFLOW™ THERMAL MANAGEMENT

KEEP CABINET

SIZES COMPACT

Heat management

Create shorter cabinets by directly stacking rows of drives. Control Techniques' unique Ultraflow™ technology expels heat directly outside the cabinet through the rear of the drive* and stops heat building up in the cabinet.

No Contamination

Ultraflow™'s guided internal airflow prevents ingress on drive circuits and, combined with conformal coating, minimizes contamination risk.

Smart fan control

An intelligently controlled fan means fans last longer and create less acoustic noise while contributing to the maximum thermal cooling by Ultraflow™.

Easy installation

Ultraflow™ requires only a 32 mm (1.25 in) hole in the cabinet meaning rapid, trouble-free installation**

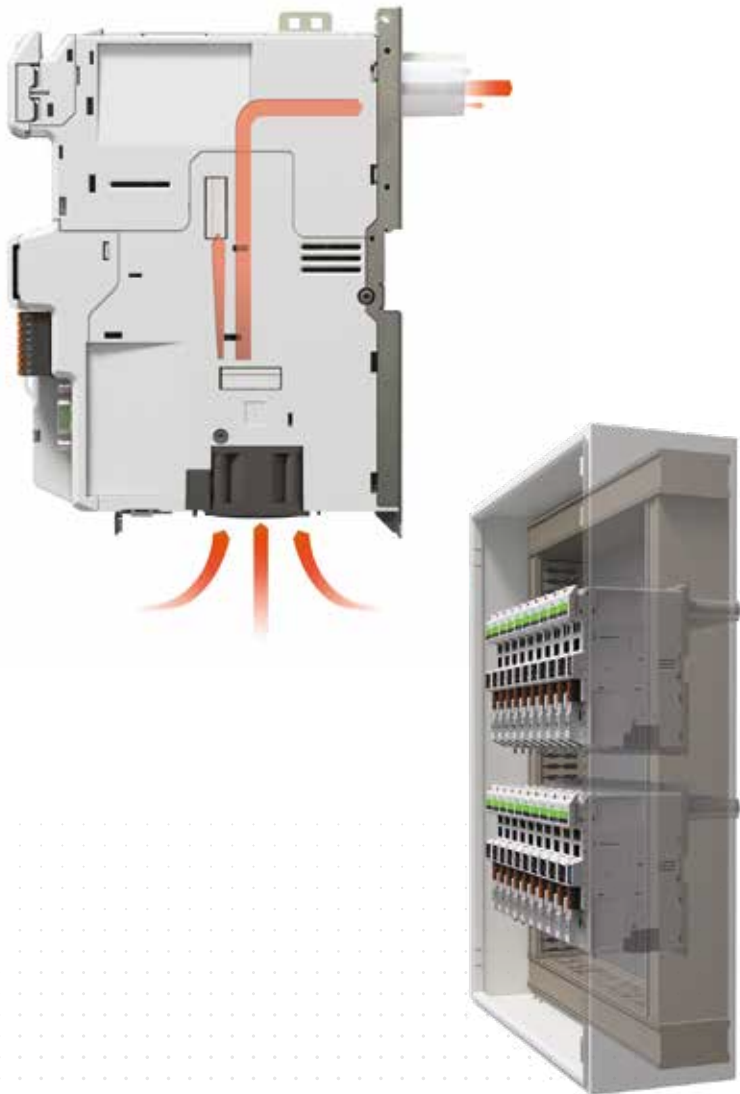

Ultraflow™ is a registered Trademark of Control Techniques
* Drive heat dissipation can also be achieved via vents on top of the drive, as standard.
** Frames 2 and 3 require 2 x 32mm (1.5 in) holes

MAXIMUM PERFORMANCE SERVO SOLUTIONS

Boost throughput with maximum control.

Get the best throughput and production quality in your machines by using Digitax HD, the perfect drive for high-dynamic applications.

- 300% peak current performance
- Optimized control loops for high dynamic performance
 - i. 62.5 μ s current loop
 - ii. 250 μ s position and speed loop
- Unique 'dead beat' current controller for maximum bandwidth
- Up to 16 kHz switching frequency (default ratings specified at 8 kHz)
- Advanced bi-quad filters for suppression of mechanical resonances

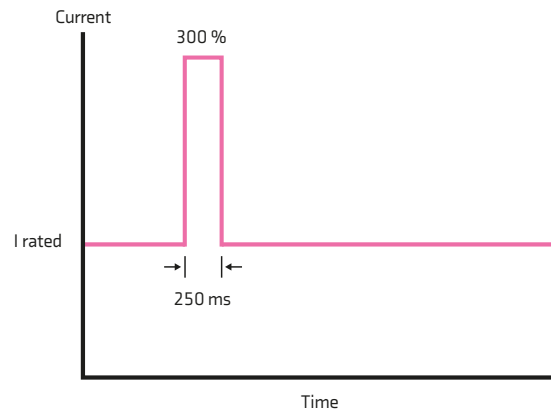

Improving accuracy through precision encoder feedback.

The flexible speed and position feedback interface supports a wide range of feedback technologies, from robust resolvers to high resolution encoders:

- Up to three onboard encoder channels simultaneously e.g. 1 feedback encoder, 1 reference encoder and 1 simulated output
- Quadrature, AB Servo, SinCos (including absolute), SSI, BiSS, EnDat 2.1/2.2, Hiperface and resolvers
- Simulated encoder output can provide position reference for cams, digital lock and electronic gearbox
- Up to 25 bit encoder resolution
- Feedback accuracy as low as $\pm 20''$

FROM STANDALONE...

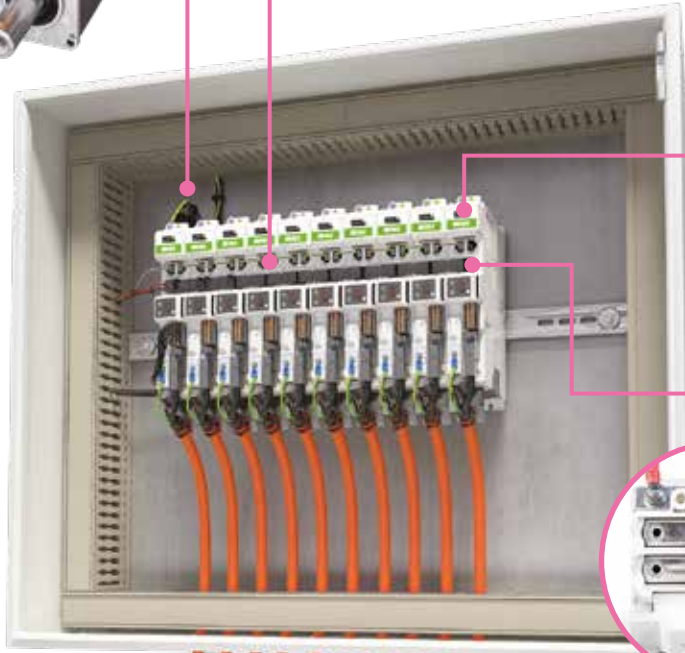

Single AC Input

Communication links

Common DC bus and earth

24 Vdc links

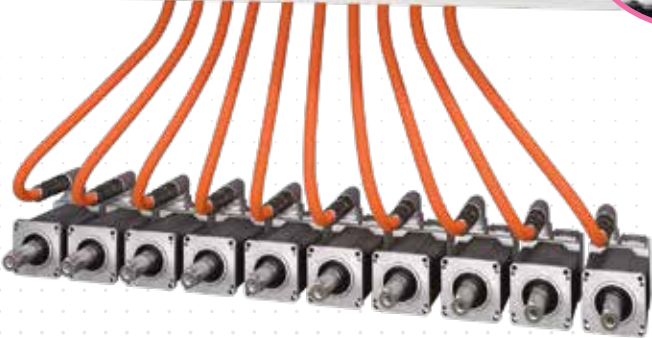

...TO A MODULAR COMMON DC BUS SYSTEM

MINIMUM EFFORT RAPID INSTALLATION

The multi-axis paralleling kit includes busbars for quick connection of DC bus and earth link, as well as Quick Links to distribute 24 Vdc supply across drives:

- Reduces installation time and cost
- Improves energy efficiency and footprint



The LED display ensures access to drive diagnostics even in the absence of network connectivity.

Includes 2 rotary switches for hardware setting of the node address for faster commissioning of the motion network.

The motor power connector is in the same position for all frame sizes, making cable routing easier and tidier.

- Easy access pluggable connectors

AC input

DC bus cover

Communication ports

24 Vdc Input

I/O

Dual Safe Torque Off (STO)

Motor earth

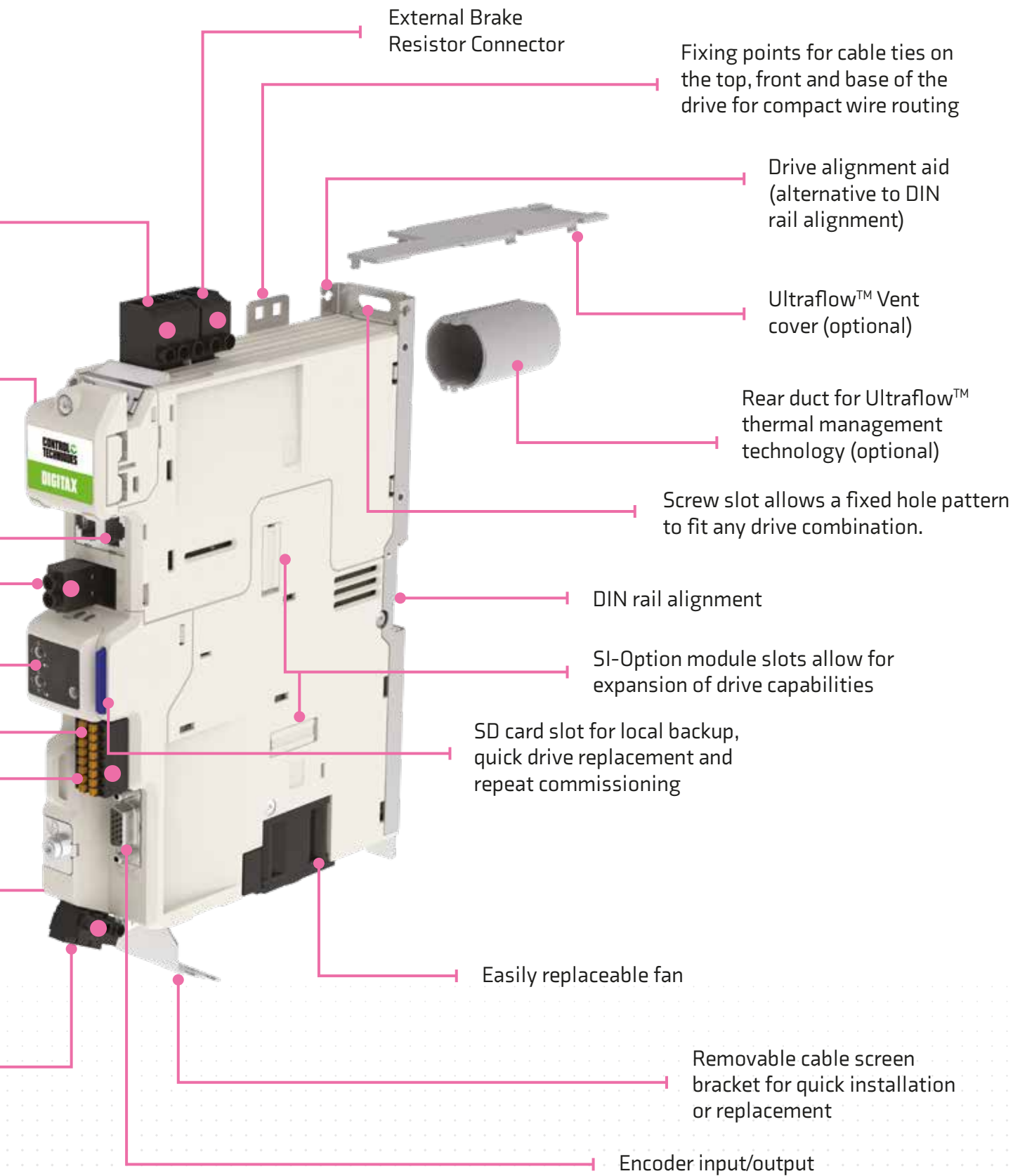

RAPID COMMISSIONING CONNECT

The Connect PC tool is for rapid commissioning, plus optimizing and monitoring drive/system performance:

- Task-based drive operations are simplified with intuitive graphical tools in a familiar Windows environment
- CTScope – a realtime software oscilloscope – facilitates tuning and monitoring
- Dynamic logic diagrams and searchable parameter listings
- Tool is scalable, through optional add-ins, to match application requirements
- Multiple communications channels for a more complete overview of the system
- Drive discovery gives the ability to find drives on a network automatically without the user having to specify their addresses
- Offline configuration



SD card

Standard SD cards can be used for quick and easy parameter and program storage.

The remote mountable keypad

Remote mountable, plain text, multi-language LCD keypad.



Single cable technology

Single cable technology with electronic motor name plate for fast setup.



Drive set-up

Quickly find everything you need for quick and easy installation of your drives.

Visit: www.drive-setup.com



Diagnostic Tool

Quickly solve any error codes that the drive may show. You can download our Diagnostics Tool app at:

controltechniques.com/mobile-applications



*For Microsoft users, please note that this mobile app operates with Windows 10 only.



APPLICATION PROGRAMMING

MACHINE

CONTROL STUDIO

Fast Programming and Commissioning

The Machine Control Studio programming environment provides a flexible and intuitive environment for programming automation and motion control features.

The software provides programming for:

- Onboard PLC
- MCI200 or MCI210 integrated machine control modules
- EtherNet network data configurations

Productivity features also supported:

- Intuitive IntelliSense functionality helps to write consistent and robust programs speeding up software development
- Programmers have access to a vibrant Open-source community for function blocks
- Machine Control Studio also supports customers' own function block libraries

Familiar automation programming languages

The programming environment is fully IEC 61131-3 compliant and therefore familiar, fast and easy to use for control engineers around the world. The following IEC 61131-3 programming languages are supported:

- Structured Text (ST)
- Function Block Diagram (FBD)
- Structured Function Chart (SFC)
- Ladder Diagram (LD)
- Instruction List (IL)
- Continuous Function Chart (CFC)





Feature	Digitax HD onboard PLC	MCI Option Module
Breakpoints	-	Yes
Source code upload/download	-	Yes
Online change	-	Yes
Trigonometric functions	-	Yes
64 bit data types	-	Yes
Real-time task(s)	Yes (min 4ms)	Yes (min 250 µs)
Customizable drive menu	Yes	Yes
Variable tracing	-	Yes
Tasks available	1 x Freewheeling task, 1 x Clock task	1 x Freewheeling task, 1 x Position task, 1 x Initial task, 4 x Clock tasks, 1 x Error task, 4 x Event tasks
Centralized controller	-	Yes
Decentralized controller	Yes	Yes

MOTION CONTROL SYSTEM ARCHITECTURE

Drive-based Motion (Decentralised/Distributed Motion Intelligence)

In a distributed motion control system, the motion control capability is distributed on-board the individual drives. This includes the position loop, motion profile and sometimes even all or part of the PLC logic.

- Each axis is fully independent, but coordination can be achieved by synchronizing drives over the network using Real-Time Motion over EtherNet (RTMoE).
- In small machines, a drive-based system can be standalone, whereas in larger systems it is more commonly connected to a PLC (or IPC) over a fieldbus which, in this case, does not need to be strictly deterministic.

Major advantages

- You receive a superior motor control performance with a drive based system because the on-board loops typically run faster and avoids the delays of network communication.
- By forgoing the need of an expensive central motion, controlled distributed motion architecture can be very cost-effective. It does this by using the onboard logic to take some load off the central PLC.
- It's really easy to scale too because the load of the PLC, where present, doesn't increase significantly with the number of drives connected.
- PC Tools also make commissioning and maintenance to a centralized solution easy.

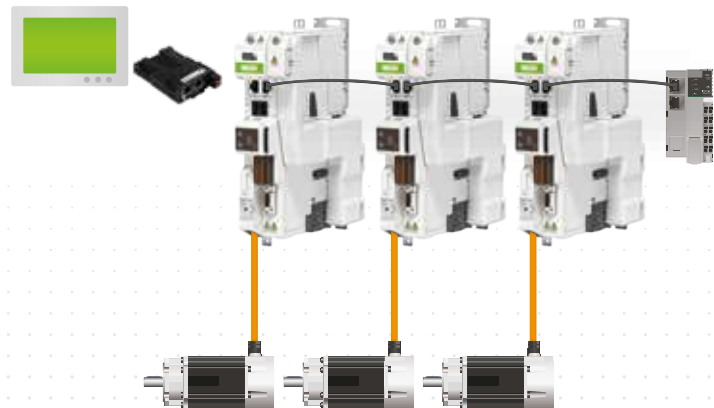

Controller-based Motion (Centralized Motion Intelligence)

A central controller generates the motion profiles of all axes. In some cases, it even closes the position loop. In this architecture, the servo drives - sometimes called amplifiers - simply follow the setpoint they receive from the controller.

- The servo drives are normally connected over an EtherNet network, using a fast and deterministic protocol such as EtherCAT.
- In modern systems, the central controller, PLC-based or IPC-based, tends to also implement all the machine logic.



M753 EtherCAT

M751 Base

Major advantages

- Coordinating the motion of multiple axes in a single program is very easy.
- Maintenance is simple because the whole machine program – and potentially even drive parameters – are stored in a single location.”

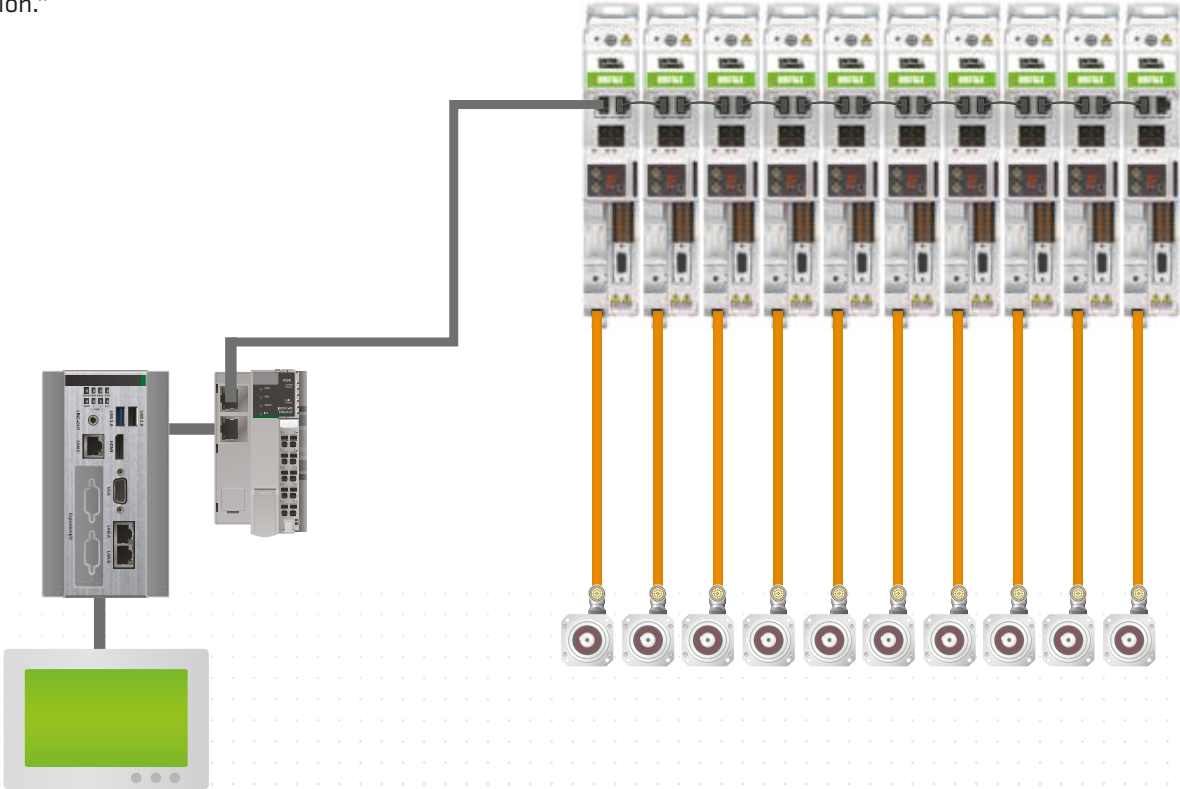

M750 ETHERNET

Multiprotocol network drive for centralized and decentralized motion applications

Digitax M750 EtherNet

- Onboard multiprotocol EtherNet, supporting Real Time Motion over EtherNet (RTMoE), EtherNet/IP, Modbus TCP/IP and PROFINET RT
- Onboard advanced motion controller for 1.5 axis motion control
- EtherNet webpages hosted onboard the M750 EtherNet drive
- Reduced downtime with machine safety
 - i. Integrated Dual Safe Torque Off
 - ii. Meets SIL3 and PLe

Advanced Motion Controller onboard

Advanced 1.5 axes motion controller, key features include:

- 250 μ s cycle time
- Interpolated cam
- Motion profile generator
- Homing functions
- Electronic gearbox
- High speed position freeze

RTMoE

Digitax HD's standard EtherNet supports RTMoE (Real-Time Motion over EtherNet) which provides synchronized communication between drives using the Precision Time Protocol as defined by IEEE1588 V2:

- Distributed clocks are used to automatically synchronize the position, speed and current loops across all drives
- High speed network synchronization of less than 1 μ s jitter (typically <200 ns) and 1 ms cycle time for synchronous cyclic data



MACHINE CONTROLLERS

Mci200 & Mci210

Second processor for PLC programs and multi-axis control

Mci200 and Mci210 modules add a powerful processor to Digitax HD. They extend the drives system and machine control capability to run application programs up to four times faster than a standard PLC.

Programs are fast and easy to develop thanks to the user-friendly Machine Control Studio software which uses industry standard IEC 61131-3 programming languages.

Mci programs can access and manage the drive embedded Advanced Motion Controller, providing perfectly synchronized multi-axis machine performance.

- Two EtherNet ports with an internal switch
- Support for standard EtherNet protocols
- RTMoE for synchronized cyclic data at 250 μs
- Modbus TCP/IP master
- Machine control over two segregated EtherNet networks enables greater flexibility in machine design
- Extended fast I/O (3 x digital inputs, 1 x digital output, 1 x digital I/O)

Segregated network control

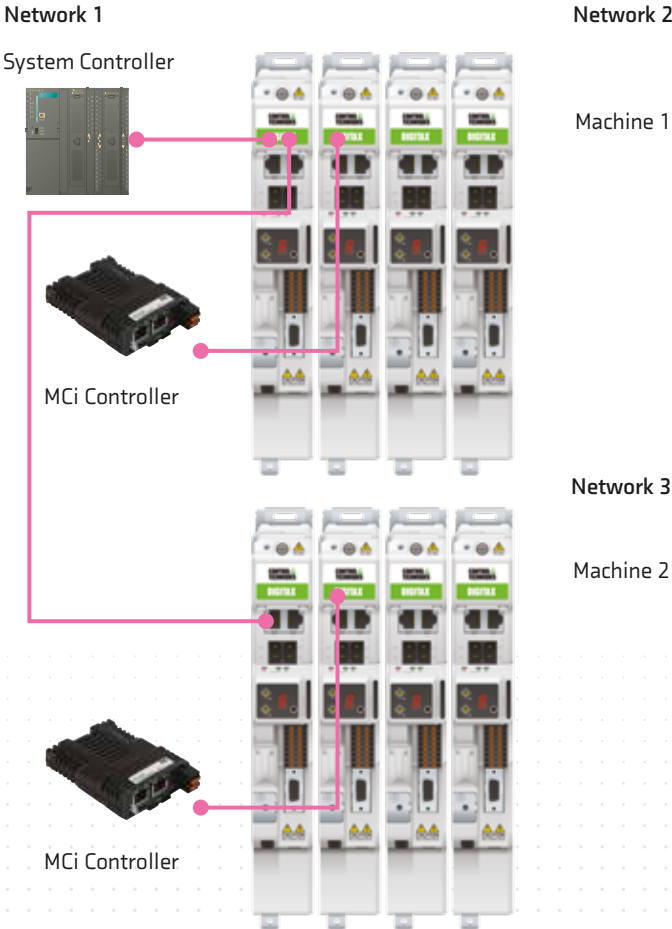

M751 BASE

Base drive for configuration flexibility

Digitax M751 flexibility

- Two option slots for functionality extension and customization – refer to page 21 for the comprehensive option module list
- Built-in Modbus RTU over RS485 communications
- Onboard Advanced Motion Controller for 1.5 axis motion control
- Analog and pulse/direction control for centralized motion
- Reduced downtime with machine safety
 - i. Integrated Dual Safe Torque Off
 - ii. Meets SIL3 and PLe

Advanced Motion Controller onboard

Advanced 1.5 axes motion controller, key features include:

- 250 μ s cycle time
- Motion profile generator
- Electronic gearbox
- Interpolated cam
- Homing functions
- High speed position freeze



M753 ETHERCAT

EtherCAT drive for centralised motion control applications

Digitax M753 EtherCAT

- Digitax M753 features an integrated 2-port EtherCAT switch for easy integration in centralized motion control applications
- EoE (EtherNet over EtherCAT) support allows PC tool connection for commissioning and monitoring over the EtherCAT network
- The station alias can be dynamically assigned by the EtherCAT master, or hardwired with the two rotary switches built into the display
- An optional RS485 adaptor is available, providing a back-up PC tool connection in case of network failure

High performance with flexibility

Operate with any automation product via EtherCAT

- Operate with motion controllers, motion PLCs and Industrial PCs via built-in EtherCAT
- Dual 100Mbps EtherCAT interfaces for use with in-line topologies
- Non-cyclic data communication using the CoE mailbox

Flexibility for all applications achieved through full access to drive functions

- CANopen over EtherCAT (CoE) including:

i. CIA-402 profile	iv. Velocity mode
ii. Cyclic sync position mode	v. Profile torque mode
iii. Interpolated position mode	vi. SDO access to all profile objects and drive parameters

Reduced downtime with machine safety

- Integrated Dual Safe Torque Off
- Meets SIL3 and PLe



OPTION MODULE FLEXIBILITY

Our innovative design means you only increase drive size when option modules are used. That means you can save oodles of space in the overall configuration.

Adding the option mounting kit adds a very small additional 22 mm (0.86 in) width, giving you a maximum drive width of 62 mm (2.44 in).



Digitax HD supports a range of communications, I/O, feedback and machine control option modules.

Feedback



SI-Universal Encoder

Encoder input and output interface supporting Quadrature, SinCos, EnDat and SSI encoders.



SI-Encoder

Quadrature encoder input interface module.

Applications with PLC or Motion Functionality



MCi200

Advanced machine control using industry standard IEC61131-3 programming languages



I/O

SI-I/O

Extended I/O interface module to increase the number of analog and digital I/O points on the drive.



MCi210

Extended advanced machine control using industry standard IEC61131-3 programming languages and integrated EtherNet connectivity

Communications



SI-EtherCAT



SI-PROFINET



SI-EtherNET*



SI-Apps Compact

Compatible module allows legacy SyPTPro application programs to be re-compiled for Digitax HD



SI-DeviceNet



SI-CANopen



SI-PROFIBUS



PTi210

PTi210 Simple, fast and effective motion control solutions using intuitive PowerTools Studio Software

* Support of real-time EtherNet (RTMoE), HTTP, SMTP, EtherNet/IP and Modbus TCP/IP

UNIMOTOR HD

HIGH DYNAMIC

SERVO MOTOR

For pulse duty applications

Unimotor HD is a high dynamic brushless AC servo motor range designed for use in pulse duty applications where rapid acceleration and deceleration is required.

High torque to inertia ratio

Unimotor HD has a high power to weight ratio, meaning that it can be easily integrated into the smallest, most demanding applications such as industrial robotics, pick & place and packaging.



Patented rotor technology

High torque to inertia ratio for high dynamic performance

Compact but powerful

Parking brake available



Supported by rigorous testing for performance and reliability

Windings to suit 400 V and 200 V

Rated speeds include 1,000 rpm – 6,000 rpm depending on motor size

Customized motor build available

IP65 conformance: sealed against water spray and dust when mounted and connected

Segmented stator design for high power density and compactness

0.7 Nm to 85.0 Nm (6.2 lb-in to 752 lb-in) and up to 300% overload

PRINTING APPLICATIONS YOU WON'T FIND BETTER



DIGITAX HD & UNIMOTOR HD MOTOR AND DRIVE COMBINATIONS



400 V range – 0.7 to 51 Nm (6.2 to 451 lb-in) with 300% peak stall torque
 200 V range – 0.7 to 45 Nm (6.2 to 398 lb-in) with 300% peak stall torque

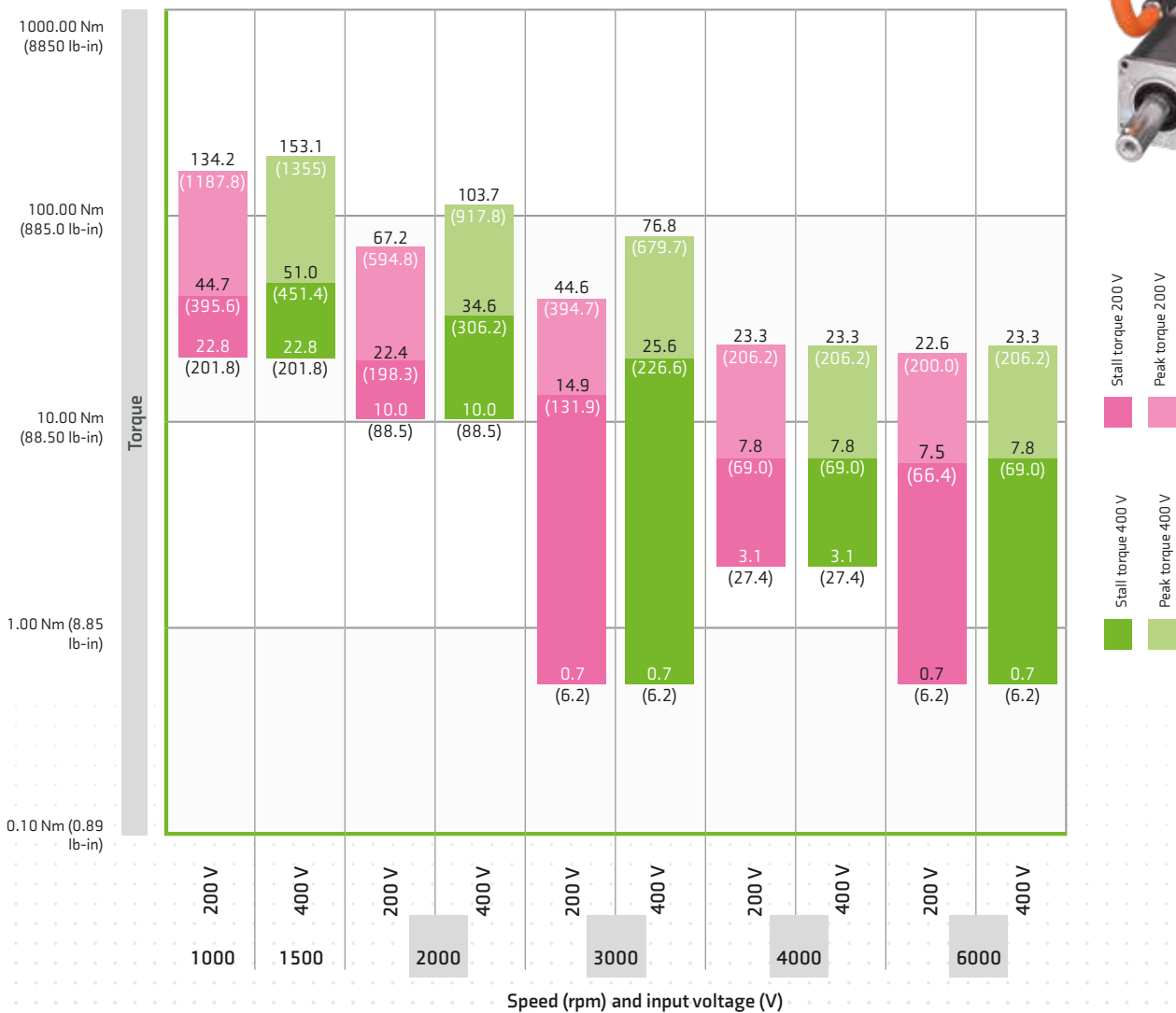

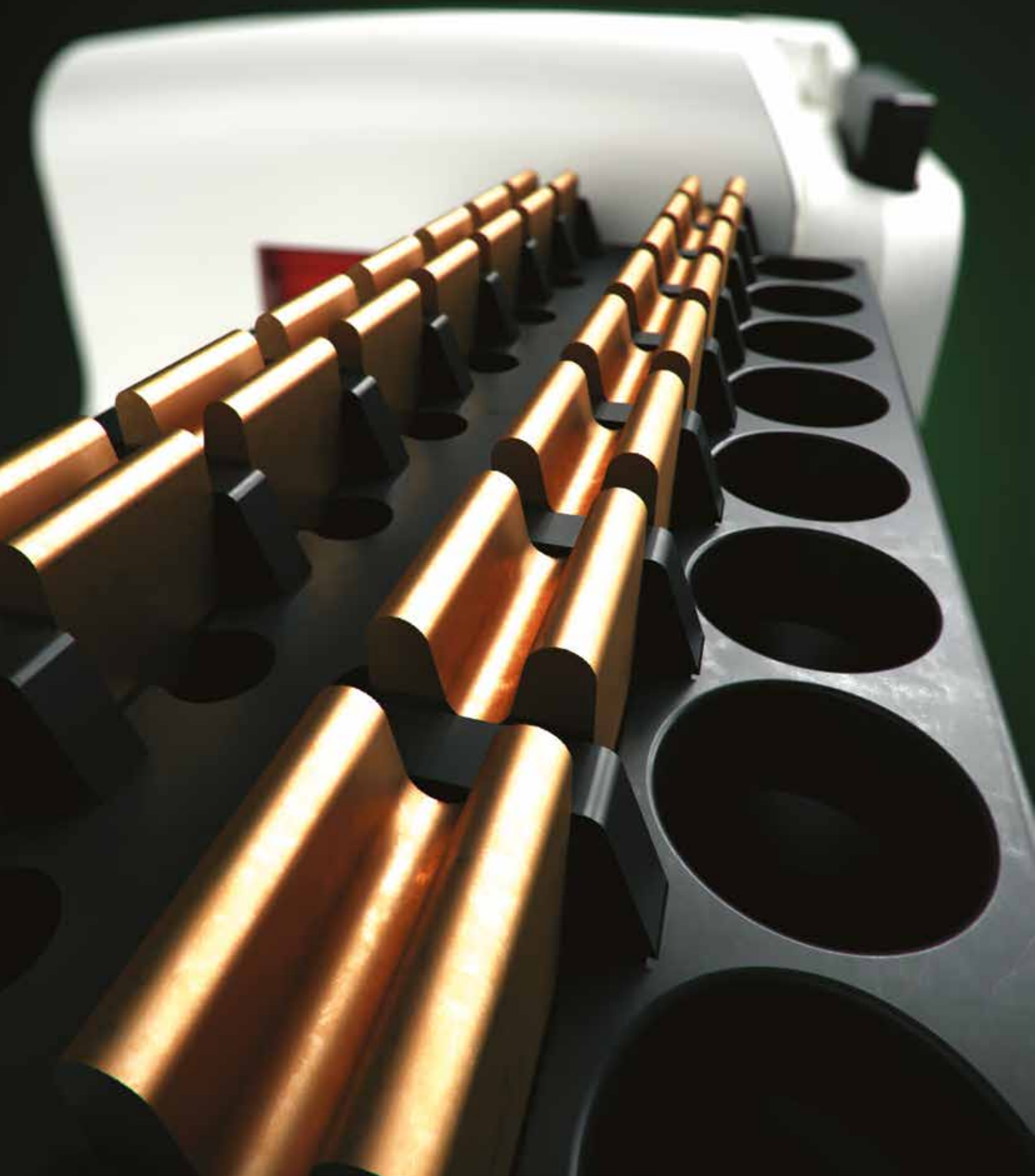

200 V Three Phase

For drive ratings, please see page 34 and motor ratings from page 38 to 43
 * Acceleration time to nominal speed is based on 1:1 motor to load inertia ratio

Nominal speed 6000 rpm - 300% overload													
Motor	Drive	Hybrid Cable	Stall Torque		Peak Torque		Inertia		Drive Cont. Current [A]	Drive Capacitance [µF]	Motor Cont. power		Time to 6000 rpm [ms]*
			[Nm]	[lb-in]	[Nm]	[lb-in]	[kg-cm ²]	[lb-in-sec ²]			[kW]	[hp]	
055EDA60	M75x-01200022	M75x-01200022	0.69	6.1	2.1	18.6	0.14	0.00012	2.2	580	0.43	0.58	8.5
055EDB60	M75x-01200040	M75x-01200040	1.1	9.7	3.4	30.1	0.25	0.00022	4	580	0.57	0.76	9.2
055EDC60	M75x-01200040	M75x-01200040	1.6	14.2	4.8	42.5	0.36	0.00032	4	580	0.75	1.01	9.5
067EDA60	M75x-01200040	M75x-01200040	1.4	12.4	4.3	38.1	0.30	0.00027	4	580	0.82	1.10	8.8
067EDB60	M75x-01200065	M75x-01200065	2.5	22.1	7.5	66.4	0.53	0.00047	6.5	580	1.4	1.88	8.9
089EDA60	M75x-02200090	M75x-02200090	3.1	27.4	9.3	82.3	0.87	0.00077	6.5	1160	1.7	2.28	11.7
089EDB60	M75x-02200120	M75x-02200120	5.3	46.9	16.0	141.6	1.6	0.00142	12	1160	2.4	3.22	12.6
089EDC60	M75x-03200160	M75x-03200160	7.5	66.4	22.6	200.0	2.3	0.00204	16	1880	3.1	4.16	13.0

Nominal speed 4000 rpm - 300% overload													
Motor	Drive	Hybrid Cable	Stall Torque		Peak Torque		Inertia		Drive Cont. Current [A]	Drive Capacitance [µF]	Motor Cont. power		Time to 4000 rpm [ms]*
			[Nm]	[lb-in]	[Nm]	[lb-in]	[kg-cm ²]	[lb-in-sec ²]			[kW]	[hp]	
089EDA40	M75x-01200065	HYBAxAxxx	3.1	27.4	9.3	82.3	0.87	0.00077	6.5	580	1.2	1.61	7.8
089EDB40	M75x-02200090	HYBAxAxxx	5.3	46.9	16.0	141.6	1.6	0.00142	9	1160	1.9	2.55	8.4
089EDC40	M75x-02200120	HYBAxAxxx	7.8	69.0	23.3	206.2	2.3	0.00204	12	1160	2.7	3.62	8.4

Nominal speed 3000 rpm - 300% overload													
Motor	Drive	Hybrid Cable	Stall Torque		Peak Torque		Inertia		Drive Cont. Current [A]	Drive Capacitance [µF]	Motor Cont. power		Time to 3000 rpm [ms]*
			[Nm]	[lb-in]	[Nm]	[lb-in]	[kg-cm ²]	[lb-in-sec ²]			[kW]	[hp]	
055EDA30	M75x-01200022	HYBAxAxxx	0.69	6.1	2.1	18.6	0.14	0.00012	2.2	580	0.21	0.28	4.2
055EDB30	M75x-01200022	HYBAxAxxx	1.1	9.7	3.4	30.1	0.25	0.00022	2.2	580	0.32	0.43	4.6
067EDA30	M75x-01200022	HYBAxAxxx	1.4	12.4	4.3	38.1	0.30	0.00027	2.2	580	0.43	0.58	4.4
055EDC30	M75x-01200022	HYBAxAxxx	1.6	14.2	4.8	42.5	0.36	0.00032	2.2	580	0.45	0.60	4.8
067EDB30	M75x-01200040	HYBAxAxxx	2.5	22.1	7.5	66.4	0.53	0.00047	4	580	0.75	1.01	4.4
089EDA30	M75x-01200040	HYBAxAxxx	2.8	24.8	8.4	74.3	0.87	0.00077	4	580	0.88	1.18	6.5
067EDC30	M75x-01200040	HYBAxAxxx	3.6	31.9	10.9	96.5	0.75	0.00066	4	580	1.1	1.48	4.3
089EDB30	M75x-01200065	HYBAxAxxx	5.3	46.9	16.0	141.6	1.6	0.00142	6.5	580	1.5	2.01	6.3
089EDC30	M75x-02200090	HYBAxAxxx	7.8	69.0	23.3	206.2	2.3	0.00204	9	1160	2.1	2.82	6.3
115EDB30	M75x-02200120	HYBAxAxxx	10.0	88.5	30.0	265.5	4.4	0.00389	12	1160	2.4	3.22	9.2
115EDC30	M75x-03200160	HYBBxAxxx	14.3	126.6	42.9	379.7	6.4	0.00566	16	1880	3.2	4.29	9.4
142EDC30	M75x-03200160	HYBBxBxxx	14.9	131.9	44.6	394.7	17.0	0.01505	16	1880	4.7	6.30	23.9

Nominal speed 2000 rpm - 300% overload													
Motor	Drive	Hybrid Cable	Stall Torque		Peak Torque		Inertia		Drive Cont. Current [A]	Drive Capacitance [μ F]	Motor Cont. power		Time to 2000 rpm [ms]*
			[Nm]	[lb-in]	[Nm]	[lb-in]	[kg-cm ²]	[lb-in-sec ²]			[kW]	[hp]	
115EDB20	M75x-02200090	HYBAxAxxx	10.0	88.5	30.0	265.5	4.4	0.00389	9	1160	1.8	2.41	6.2
115EDC20	M75x-02200120	HYBAxAxxx	14.3	126.6	42.9	379.7	6.4	0.00566	12	1160	2.4	3.22	6.2
115EDD20	M75x-03200160	HYBBxAxxx	18.4	162.9	55.3	489.4	8.4	0.00743	16	1880	3.2	4.29	6.4
142EDC20	M75x-03200160	HYBBxBxxx	22.4	198.3	67.2	594.8	17.0	0.01505	16	1880	4.1	5.50	10.6

Nominal speed 1000 rpm - 300% overload													
Motor	Drive	Hybrid Cable	Stall Torque		Peak Torque		Inertia		Drive Cont. Current [A]	Drive Capacitance [μ F]	Motor Cont. power		Time to 1000 rpm [ms]*
			[Nm]	[lb-in]	[Nm]	[lb-in]	[kg-cm ²]	[lb-in-sec ²]			[kW]	[hp]	
142EDC10	M75x-02200090	HYBAxAxxx	22.8	201.8	68.3	604.5	17.0	0.01505	9	1160	2.2	2.95	5.2
142EDD10	M75x-02200120	HYBAxAxxx	28.7	254.0	86.0	761.2	22.1	0.01956	12	1160	2.8	3.75	5.4
142EDE10	M75x-03200160	HYBBxAxxx	34.6	306.2	103.7	917.8	27.2	0.02407	16	1880	3.3	4.43	5.5
190EDC10	M75x-03200160	HYBBxBxxx	44.7	395.6	134.2	1187.8	54.6	0.04833	16	1880	4.7	6.30	8.5

400 V Three Phase

For drive ratings, please see page 36 and motor ratings from page 40 to 45.
* Acceleration time to nominal speed is based on 1:1 motor to load inertia ratio

Nominal speed 6000 rpm - 300% overload													
Motor	Drive	Hybrid Cable	Stall Torque		Peak Torque		Inertia		Drive Cont. Current [A]	Drive Capacitance [μ F]	Motor Cont. power		Time to 6000 rpm [ms]*
			[Nm]	[lb-in]	[Nm]	[lb-in]	[kg-cm ²]	[lb-in-sec ²]			[kW]	[hp]	
055UDA60	M75x-01400015	HYBAxAxxx	0.69	6.1	2.1	18.6	0.14	0.00012	1.5	110	0.43	0.6	8.5
055UDB60	M75x-01400015	HYBAxAxxx	1.1	9.7	3.4	30.1	0.25	0.00022	1.5	110	0.57	0.8	9.2
055UDC60	M75x-01400030	HYBAxAxxx	1.6	14.2	4.8	42.5	0.36	0.00032	4.2	110	0.75	1.0	9.5
067UDA60	M75x-01400030	HYBAxAxxx	1.4	12.4	4.3	38.1	0.30	0.00027	4.2	110	0.82	1.1	8.8
067UDB60	M75x-01400042	HYBAxAxxx	2.5	22.1	7.5	66.4	0.53	0.00047	4.2	110	1.4	1.9	8.9
067UDC60	M75x-02400060	HYBAxAxxx	3.6	31.9	10.9	96.5	0.75	0.00066	6.0	290	1.9	2.5	8.7
089UDA60	M75x-01400042	HYBAxAxxx	3.1	27.4	9.3	82.3	0.87	0.00077	4.2	110	1.7	2.3	11.7
089UDB60	M75x-02400080	HYBAxAxxx	5.3	46.9	16.0	141.6	1.6	0.00142	8.0	290	2.4	3.2	12.6
089UDC60	M75x-02400105	HYBBxAxxx	7.8	69.0	23.3	206.2	2.3	0.00204	10.5	290	3.1	4.2	12.6

Nominal speed 4000 rpm - 300% overload													
Motor	Drive	Hybrid Cable	Stall Torque		Peak Torque		Inertia		Drive Cont. Current [A]	Drive Capacitance [μ F]	Motor Cont. power		Time to 4000 rpm [ms]*
			[Nm]	[lb-in]	[Nm]	[lb-in]	[kg-cm ²]	[lb-in-sec ²]			[kW]	[hp]	
089UDA40	M75x-01400030	HYBAxAxxx	3.1	27.4	9.3	82.3	0.87	0.00077	4.2	110	1.2	1.6	7.8
089UDB40	M75x-02400060	HYBAxAxxx	5.3	46.9	16.0	141.6	1.6	0.00142	6.0	290	1.9	2.5	8.4
089UDC40	M75x-02400080	HYBAxAxxx	7.8	69.0	23.3	206.2	2.3	0.00204	8.0	290	2.7	3.6	8.4

Nominal speed 3000 rpm - 300% overload													
Motor	Drive	Hybrid Cable	Stall Torque		Peak Torque		Inertia		Drive Cont. Current [A]	Drive Capacitance [µF]	Motor Cont. power		Time to 3000 rpm [ms]*
			[Nm]	[lb-in]	[Nm]	[lb-in]	[kg-cm ²]	[lb-in-sec ²]			[kW]	[hp]	
055UDA30	M75x-01400015	HYBAxAxxx	0.69	6.1	2.1	18.6	0.14	0.00012	1.5	110	0.21	0.3	4.2
055UDB30	M75x-01400015	HYBAxAxxx	1.1	9.7	3.4	30.1	0.25	0.00022	1.5	110	0.32	0.4	4.6
055UDC30	M75x-01400015	HYBAxAxxx	1.6	14.2	4.8	42.5	0.36	0.00032	1.5	110	0.45	0.6	4.8
067UDA30	M75x-01400030	HYBAxAxxx	1.4	12.4	4.3	38.1	0.30	0.00027	4.2	110	0.43	0.6	4.4
067UDB30	M75x-01400015	HYBAxAxxx	2.4	21.2	7.2	63.7	0.53	0.00047	1.5	110	0.75	1.0	4.6
067UDC30	M75x-01400030	HYBAxAxxx	3.6	31.9	10.9	96.5	0.75	0.00066	4.2	110	1.1	1.5	4.3
089UDA30	M75x-01400030	HYBAxAxxx	3.1	27.4	9.3	82.3	0.87	0.00077	4.2	110	0.91	1.2	5.9
089UDB30	M75x-01400042	HYBAxAxxx	5.3	46.9	16.0	141.6	1.6	0.00142	4.2	110	1.5	2.0	6.3
089UDC30	M75x-02400060	HYBAxAxxx	7.8	69.0	23.3	206.2	2.3	0.00204	6.0	290	2.1	2.8	6.3
115UDB30	M75x-02400080	HYBAxAxxx	10.0	88.5	30.0	265.5	4.4	0.00389	8.0	290	2.4	3.2	9.2
115UDC30	M75x-02400105	HYBBxAxxx	14.3	126.6	42.9	379.7	6.4	0.00566	10.5	290	3.2	4.3	9.4
115UDD30	M75x-03400135	HYBBxAxxx	18.4	162.9	55.3	489.4	8.4	0.00743	13.5	470	4.2	5.6	9.5
142UDC30	M75x-03400160	HYBBxAxxx	22.8	201.8	68.3	604.5	17.0	0.01505	16.0	470	5.3	7.1	15.7
142UDD30	M75x-03400160	HYBBxBxxx	25.6	226.6	76.8	679.7	22.1	0.01956	16.0	470	6.0	8.0	18.1

Nominal speed 2000 rpm - 300% overload													
Motor	Drive	Hybrid Cable	Stall Torque		Peak Torque		Inertia		Drive Cont. Current [A]	Drive Capacitance [µF]	Motor Cont. power		Time to 2000 rpm [ms]*
			[Nm]	[lb-in]	[Nm]	[lb-in]	[kg-cm ²]	[lb-in-sec ²]			[kW]	[hp]	
115UDB20	M75x-01400042	HYBAxAxxx	10.0	88.5	30.0	265.5	4.4	0.00389	4.2	110	1.8	2.4	6.2
115UDC20	M75x-02400060	HYBAxAxxx	14.3	126.6	42.9	379.7	6.4	0.00566	6.0	290	2.4	3.2	6.2
115UDD20	M75x-02400080	HYBAxAxxx	18.4	162.9	55.3	489.4	8.4	0.00743	8.0	290	3.2	4.3	6.4
142UDC20	M75x-02400105	HYBBxAxxx	22.8	201.8	68.3	604.5	17.0	0.01505	10.5	290	4.1	5.5	10.4
142UDD20	M75x-03400135	HYBBxAxxx	28.7	254.0	86.0	761.2	22.1	0.01956	13.5	470	4.9	6.6	10.8
142UDE20	M75x-03400160	HYBBxAxxx	34.6	306.2	103.7	917.8	27.2	0.02407	16.0	470	5.6	7.5	11.0

Nominal speed 1500 rpm - 300% overload													
Motor	Drive	Hybrid Cable	Stall Torque		Peak Torque		Inertia		Drive Cont. Current [A]	Drive Capacitance [µF]	Motor Cont. power		Time to 1500 rpm [ms]*
			[Nm]	[lb-in]	[Nm]	[lb-in]	[kg-cm ²]	[lb-in-sec ²]			[kW]	[hp]	
142UDC15	M75x-02400080	HYBAxAxxx	22.8	201.8	68.3	604.5	17.0	0.01505	8.0	290	3.2	4.3	7.8
142UDD15	M75x-02400105	HYBAxAxxx	28.7	254.0	86.0	761.2	22.1	0.01956	10.5	290	3.9	5.2	8.1
142UDE15	M75x-03400135	HYBAxAxxx	34.6	306.2	103.7	917.8	27.2	0.02407	13.5	470	4.5	6.0	8.2
190UDC15	M75x-03400160	HYBBxBxxx	51.0	451.4	153.1	1355.0	54.6	0.04833	16.0	470	7.3	9.8	11.2



MODULAR MULTI-AXIS CONFIGURATION

Dimensioning the common DC bus

4 easy steps to accurately dimension your system

- 1 Choose drive & motor combination based on speed and torque requirements [see pages 31 and 33](#)
- 2 Note nominal power & drive capacitance for each combination
- 3 Choose the drive to act as power supply for the drive group. Usually the largest drive
- 4 Check that:
 - sum of drive capacitance <= maximum capacitance**
 - sum of nominal power <= maximum input power**
 (Refer to tables opposite)

Digitax HD drives have a high capacity input power stage, allowing for a group of drives on a common DC bus to be powered by a single AC connection.

Alternatively, for larger configurations an external DC source can be used, such as a larger frame Unidrive M.

* External AC Line Reactor required. Please refer to the Installation and Technical Guide.
 ** If any of the values are exceeded, the system needs to be split in groups and the procedure repeated for each group.

200V					
		Max Capacitance (µF)	Internal Capacitance (µF)	Max Input Power (kW)	Max Input Power (hp)
Size 1	M75x-01200022				
	M75x-01200040	5800	580	4 / 5.2*	5.4 / 7.0*
	M75x-01200065				
Size 2	M75x-02200090	4640	1160	5.3 / 6.9*	7.1 / 9.3*
	M75x-0220012				
Size 3	M75x-03200160	3760	1880	6.3 / 10*	8.5 / 13.4*

400V					
		Max Capacitance (µF)	Internal Capacitance (µF)	Max Input Power (kW)	Max Input Power (hp)
Size 1	M75x-01400015				
	M75x-01400030	1900	110	6.5 / 8.5*	8.7 / 11.4*
	M75x-01400042				
Size 2	M75x-02400060				
	M75x-02400080	2030	290	8.7 / 11.4*	11.7 / 15.3*
	M75x-02400105				
Size 3	M75x-03400135	2210	470	10 / 13*	13.4 / 17.4*
	M75x-03400160				

NOTE: The number of drives that can be connected on a common DC bus group depends on the total installed capacitance, the power rating of the input stage and the power profile of each axis. There is also a limit of 10 drives for the 24 Vdc link.

For optimized dimensioning please refer to the Installation and Technical Guide.









KITS AND ACCESSORIES

Multi-axis Kit		
Order code	Accessory	Description
9500-1047		Multi-axis Kit (standard – without SI-Option Mounting Kit fitted)
9500-1048		Multi-axis Kit (with SI-Option Mounting Kit fitted)
Order code	Accessory	Description
3470-0145		External Cable Grommet Kit up to 6mm ²
9500-1050		Multi-axis Kit (with SI-Option Mounting Kit fitted)
4500-0096		USB to EIA485 Communications Converter Cable
82700000020300		KI-Compact 485 Adaptor
82700000020400		KI-Compact Display









Standard cables available
Refer to pages 33 and 34

Order code	Accessory	Description
4401-0236		Input Line Choke
82400000019600		Remote Keypad RTC
3470-0158		Frame 1 Rear Ultraflow™ Vent Kit
3470-0181		Frame 2/3 Rear Ultraflow™ Vent Kit
3470-0185		Retrofit Kit – Epsilon 202-206
3470-0184		Retrofit Kit – Epsilon 209-216
3470-0182		Retrofit Kit – Digitax ST/SP0
3470-0183		Retrofit Kit – M'Ax
9500-1055		SI-Option Mounting Kit

Drive – Mountable Brake Resistor

Order code	Accessory	Description
9500-1049		Compact Brake Resistor Kit – 50 W, 70 Ω

External Brake Resistor

Order code	Accessory	Description
1220-2201		External Brake Resistor – DBR 100 W, 20 Ω
1220-2401		External Brake Resistor – DBR 100 W, 40 Ω
1220-2801		External Brake Resistor – DBR 100 W, 80 Ω

Order code	Accessory	Description
9500-1053		Fan Replacement Kit (frame 1 and 2)
9500-1054		Fan Replacement Kit (frame 3)
82700000020200		Encoder breakout kit

KITS AND ACCESSORIES

EMC Filters

Voltage	Model (M75X-...)	Phases	Order code
200 V	1200022	1	
	1200040	1	4200-3503
	1200065	1	
	2200090	1	4200-5033
	2200120	1	
	3200160	1	4200-6034
	1200022	3	4200-8744
	1200040	3	4200-6002
	1200065	3	4200-6001
	2200090	3	4200-5833
400 V	2200120	3	4200-5833
	3200160	3	4200-5833
	01400015 to 01400042	3	4200-8744
	02400060 to 02400105	3	4200-1644
	03400135 to 03400160	3	4200-5833
	* Multi-axis up to 46 A		4200-0033
	* Multi-axis up to 60.2 A		4200-5534
	* Multi-axis up to 82.2 A		4200-7534
	* Multi-axis up to 109.5 A		4200-0035

* EMC filter ratings provided at maximum continuous current at 40 °C (104 °F). Please refer to the installation and Technical Guide.





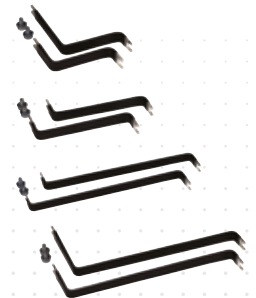









Description	Order code
DC bus conn. kit - Unidrive M fr03 (panel mount)	3470-0146
DC bus conn. kit - Unidrive M fr03 (through mount)	3470-0147
DC bus conn. kit - Unidrive M fr06 (panel mount)	3470-0148
DC bus conn. kit - Unidrive M fr06 (through mount)	3470-0149



System Integration Option Modules



Option		Order code
MCI200		82400000017000
MCI210		82400000016700
SI-Apps Compact		82400000020700
SI-EtherNet		82400000017900
SI-PROFINET RT		82500000018200
SI-PROFIBUS		82400000017500
SI-CANopen		82400000017600
SI-DeviceNet		82400000017700
SI-Universal Encoder		82400000018300
SI-Encoder		82400000018100
SI-I/O		82400000017800
SI-EtherCAT		82400000018000
PTi210		82400000021400

In the box for each Digitax HD M75x

Description	Part Number	M750 EtherNet	M751 Base	M753 EtherCAT	M75C CapShare
KI-Compact Display	82700000020400	Yes	No	Yes	N/A
SI-Option Mounting Kit	9500-1055	No	Yes	No	N/A
Removable cable screen bracket		Yes	Yes	Yes	N/A
Brake Connector		Yes	Yes	Yes	N/A
Power Input Connector		Yes	Yes	Yes	N/A
24 Vdc Supply Input Connector		Yes	Yes	Yes	Yes
I/O Connector		Yes	Yes	Yes	N/A
Motor Connector		Yes	Yes	Yes	N/A
M4 x 8 Screws (Motor earth, Input earth and cable screen bracket)		Yes	Yes	Yes	N/A

M75C CAPSHARE CAPACITOR MODULE

M75C Capabilities

Available in 200 V and 400 V variants, the M75C CapShare Capacitor Module is contained within a M75x Frame 1 chassis measuring 40mm width. M75C CapShare is designed for use in multi-axis applications to offer:

- Ways to cope with fluctuations in power supply by increasing the ability to ride through short cut outs in mains power
- Dynamic performance with quick-access energy storage for fast acceleration / deceleration
- Energy efficiency as more energy can be stored rather than being wasted as heat

Multiple M75C CapShare units can be paralleled in a scalable architecture, which is also quick and easy to install with DIN rail alignment, and easy DC bus paralleling.

Energy efficiency

- Easy common DC bus connection enables braking energy to be recycled within the drive system, optimizing energy usage.
- Any Digitax HD drive can be used as an Active Front End (AFE) to create a regenerative AC drive system.

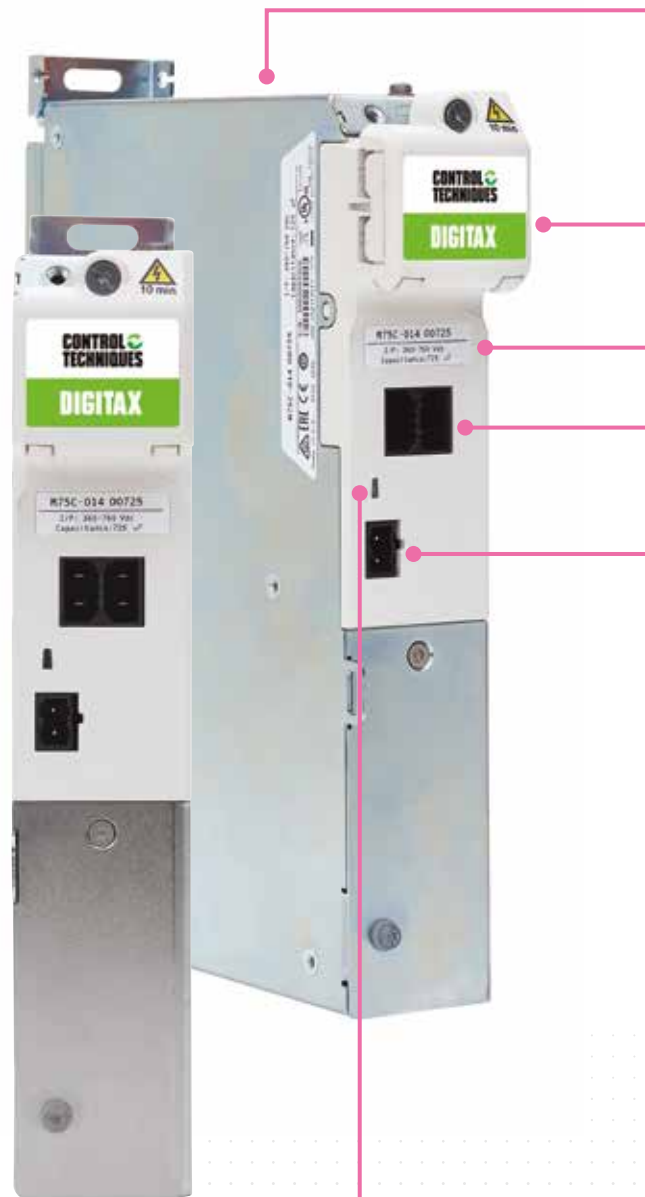

Status LED

- Top vent for natural convection cooling
- Common DC bus links & parallel connection
- DIN rail alignment
- 24 Vdc parallel connection
- Status relay contacts

M75C CapShare Capacitor Module

Part Number	M75C-01201740	M75C-01400725
Rated Voltage	200 V	400 V
Onboard capacitance	1740 µF	725 µF
DC supply	200-370 Vdc	360-760 Vdc
External 24 Vdc supply for control		Yes
Internal Current Inrush limitation Circuit		Yes
Status Relay (Potential Free Contacts)		Yes
Status Indication On Front Panel		Single LED
Thermal Protection		Yes

Easy connection to a drive or drive group can be achieved with the multiaxis kit (9500-1048) – no additional fusing required.

Active Front End Kits

Voltage	Model (M75X-...)	Switching Frequency Filter Capacitors	Regenerative Choke	Switching Frequency Filter Choke
		Order Codes	Order Codes	Order Codes
200 V	2200090	1610-8104	4401-0310	4401-1311
	2200120	1610-8104	4401-0312	4401-1312
	3200160	1610-8104	4401-0313	4401-1313
400 V	2400080	1610-8104	4401-0405	4401-0162
	2400105	1610-8104	4401-0406	4401-0163
	3400135	1610-8104	4401-0407	4401-0164
	3400160	1610-8104	4401-0407	4401-0164

DIGITAX HD DRIVES

Part number key

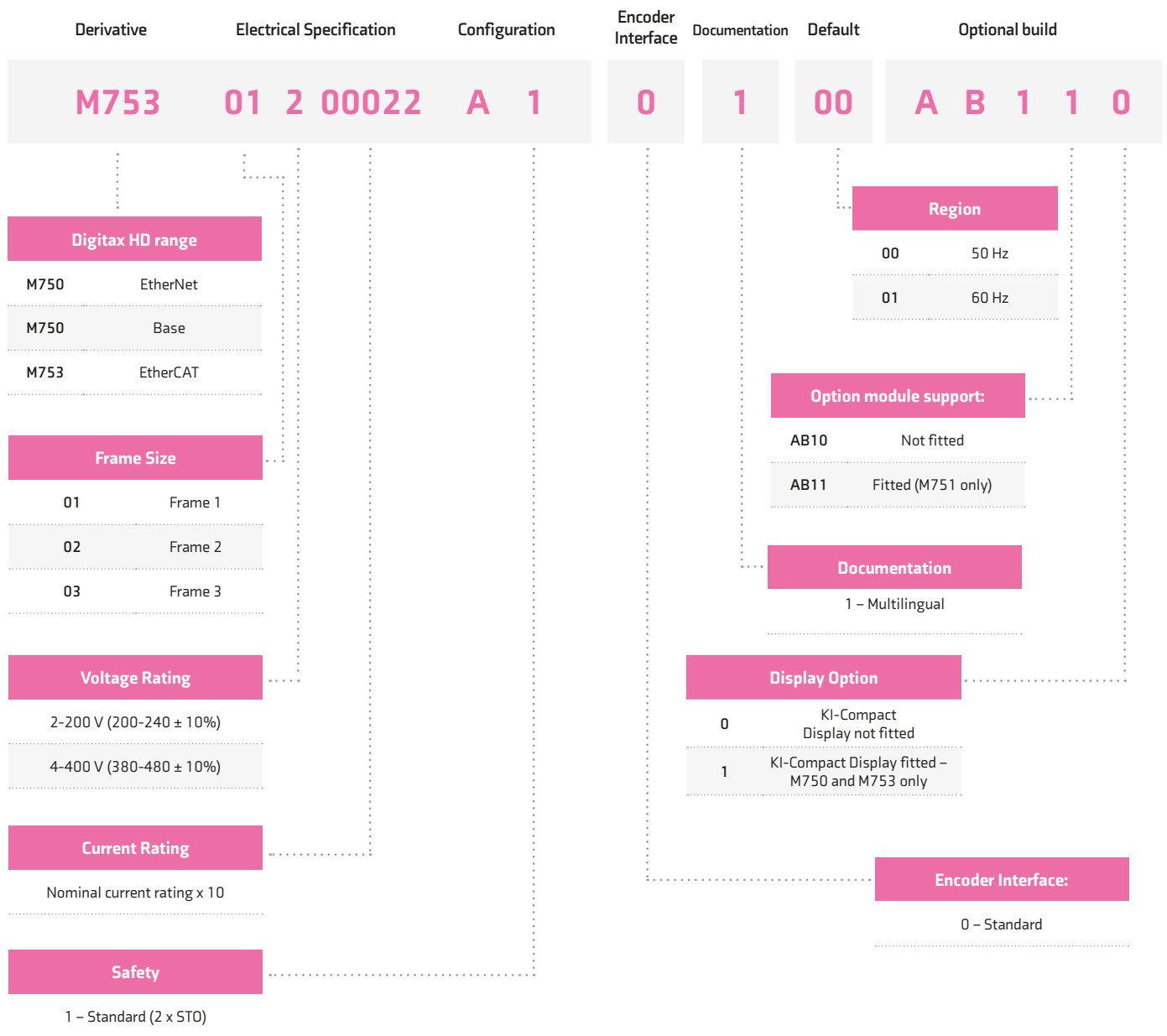

UNIMOTOR HD MOTORS

Part number key

Frame Size	Motor Voltage	Stator Length	Rated Speed	Brake	Connection Type	Output Shaft	Feedback Device	Inertia + thermistor type
089	UD	B	30	0	B	A	CA	A

055 067 089 115 142 190	ED = 200V UD = 400V	<p>0 = Not fitted</p> <p>S = Parking Brake (fibre)</p> <p>6 = Parking Brake (resin)</p> <p>x = Special</p>	<p>Size 1</p> <p>B = Power and signal 90° rotatable</p> <p>D = Single cable, power & Signal combined, 90° rotatable</p> <p>Size 1.5</p> <p>J = Power and signal 90° rotatable</p> <p>E = Single cable, power & signal combined, 90° rotatable</p> <p>Single cable only must be fitted with KTY thermistor and is only available with certain feedback options. Please check before ordering.</p>	<p>A = Key</p> <p>B = Plain</p> <p>E = Key with half key fitted</p> <p>F = Key and half key supplied separately*</p>	<p>A = Standard + PTC</p> <p>C = Standard inertia + KTY84-130 Thermistor</p> <p>E = Standard + PTC Thermistor + Lifting brackets (190 frame)</p>
--	------------------------	--	--	--	--

Code	Type	Incremental Resolution	Absolute Resolution	Accuracy	Single Cable
055 to 067 Frame Sizes					
AR	Resolver	14 bit	-	±600"	no
EG	Absolute (Multi turn)	19 bit	12 bit	±120"	yes
FG	Absolute (Single turn)	19 bit	-	±120"	yes
TL	Absolute (Multi turn)	17 bit	12 bit	±120"	no
UL	Absolute (Single turn)	17 bit	-	±120"	no
089 to 190 Frame Sizes					
AE	Resolver	14 bit	-	±720"	no
EF	Absolute (Multi turn)	19 bit	12 bit	±65"	yes
FF	Absolute (Single turn)	19 bit	-	±65"	yes
RA	Absolute (Multi turn)	20 bit	12 bit	±52"	no
SA	Absolute (Single turn)	20 bit	-	±52"	no

Additional feedback options available on request.

¹ not available for 055 & 190 frames

² not available on 055 frame.

*For stator length and connection type see pages 38 - 43

CABLES AND CONNECTIONS

POWER CABLE

Part number key

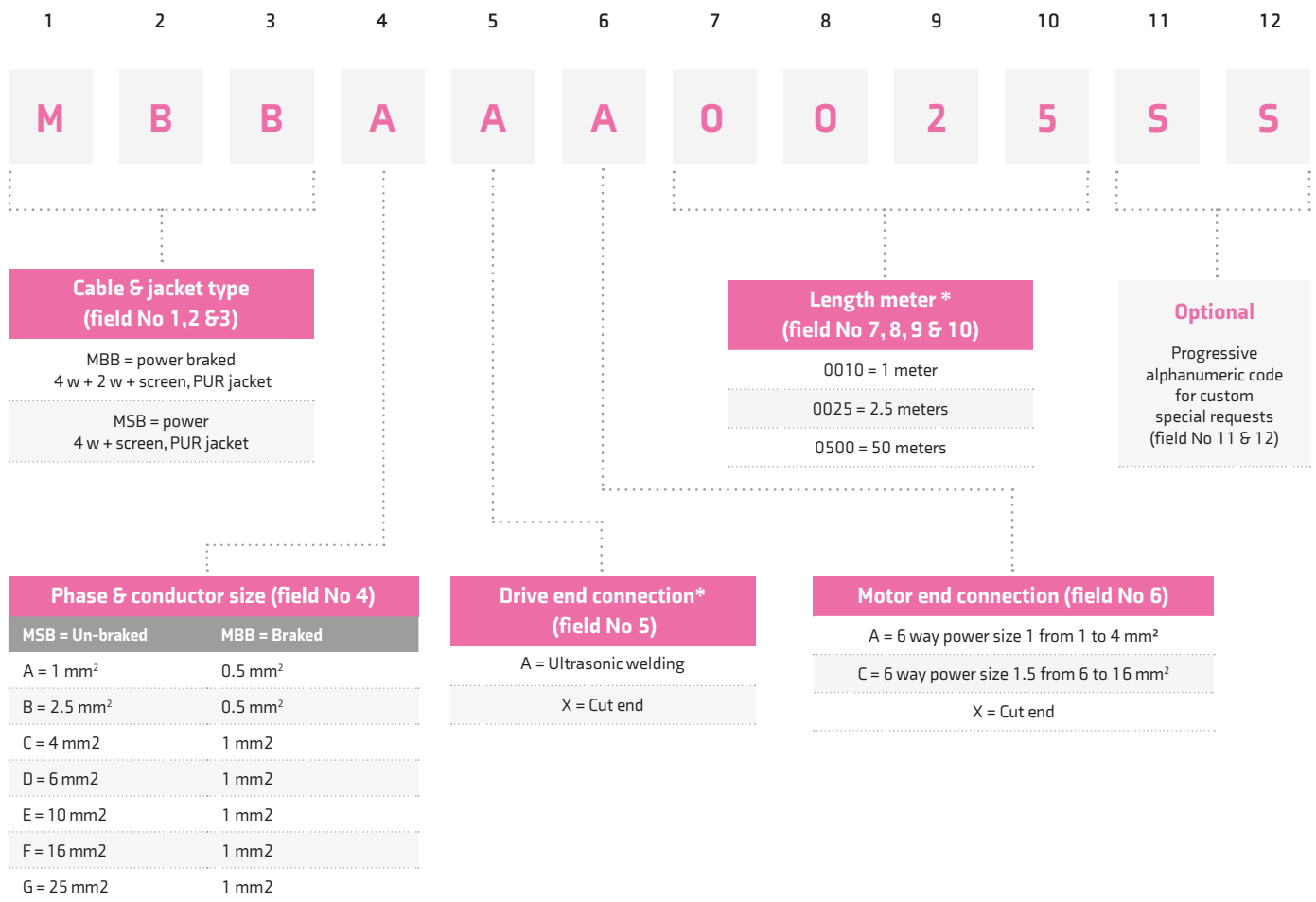

*Length meter / cable requiring (cm) lengths will be rounded up to the next highest half meter; Eg. 2.1 will be changed to a 2.5 meter cable.
Maximum cable length refer to page 34

CABLES AND CONNECTIONS

SINGLE CABLE

Part number key

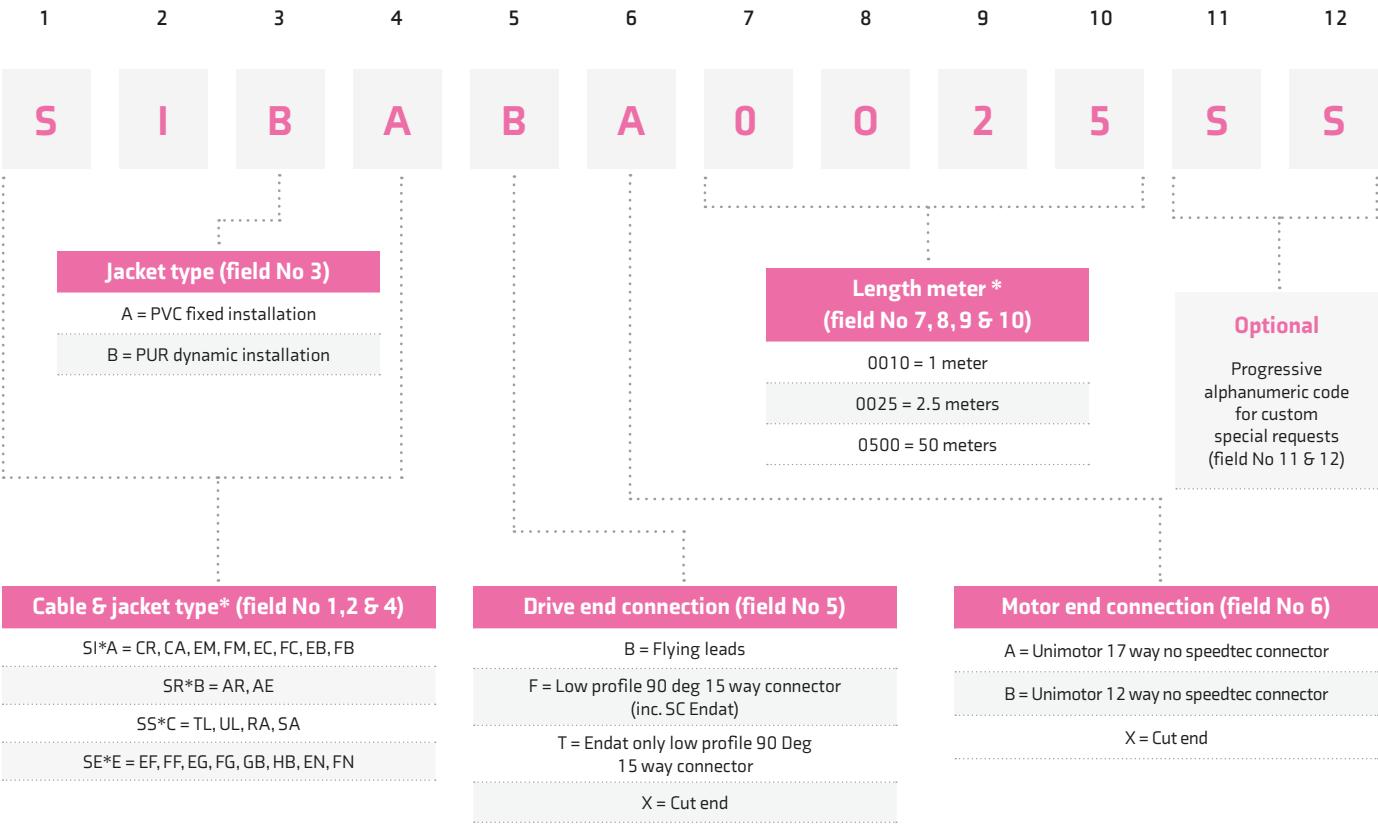

* Length meter/cable requiring (cm) lengths will be rounded up to the next highest half meter; Eg. 2.1 will be changed to a 2.5 meter cable.
Maximum cable length refer to page 34

CABLES AND CONNECTIONS

HYBRID CABLE

Part number key

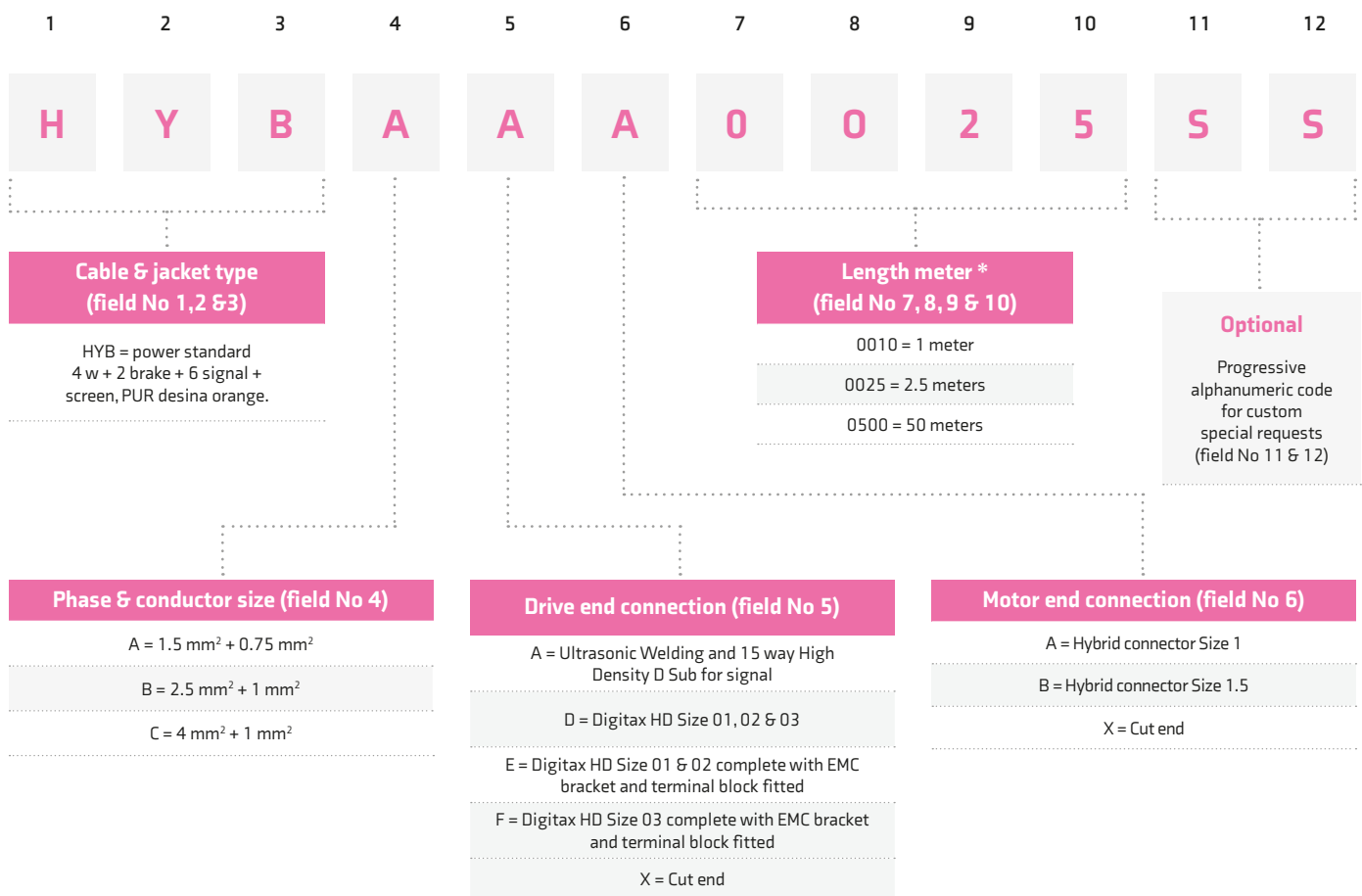

* Length meter / cable requiring (cm) lengths will be rounded up to the next highest half meter; Eg. 2.1 will be changed to a 2.5 meter cable
 Maximum cable assembly length refer to table overleaf

DIGITAX HD

SPECIFICATION

Servo Series Specification		M753 EtherCAT	M751 Base	M750 EtherNet	M751 + MCI210
Performance	Update Rates	Current Loop Update: 62 µs			
		Speed Loop Update: 250 µs			
		Position Loop Update: 250 µs			
	Overload	*Closed-loop Overload: Maximum closed loop peak current for 0.25 s (from cold: 300 % for 8 s or 200 % for 60 s)			
		*Open-loop Overload: Maximum open loop peak current for 8 s (from cold: 150 % for 100 s)			
Max Output Frequency	550 Hz (RFC-A and RFC-S) 599 Hz (Open Loop)				
Switching Frequency	Configurable range: 2, 3, 4, 6, 8, 12, 16 kHz				
	Default: 8kHz				
Ultraflow™ Technology	Adjustable Venting	Top venting or rear venting (with optional kit)			
	Intelligent Fan Control	Temperature controlled fan operation with user adjustable speed limit			
	Managed Internal Airflow	Managed airflow for maximum ingress protection			
Onboard Intelligence	Motion	Advanced Motion Controller			MCI210
		Parameterised motion			Programmable motion
		1.5 Axes			Up to 5 Axes
	Positioning digital lock control			Positioning digital lock control camming	
	Real-time tasks				
PLC	Onboard PLC			Onboard Machine Controller	
	IEC61131-3 programming (IL, LD, FBD, SFC, ST, CFC)				
Control	Motor Control Modes	V/F, Open loop vector, Rotor flux control-Asynchronous for induction motors (Sensorless or with feedback 'Closed Loop'), Rotor flux control-Synchronous (Sensorless or with feedback 'Closed Loop')			
	Control Modes	Position control, speed control, torque control			
	Control Features	Stationary autotune for permanent magnet motors			
Advanced bi-quad filters for suppression of mechanical resonances					

		M753 EtherCAT	M751 Base	M750 EtherNet	M751 + MCI210
Interface	Onboard Communications	2-port EtherCAT switch	2-port RS485	2-port EtherNet switch	2-port RS 485 2-port EtherNet switch
	Fieldbus	EtherCAT	Modbus RTU	Modbus RTU, Modbus TCP/IP, EtherNet/IP, PROFINET RT	Modbus RTU, Modbus TCP/IP, EtherNet/IP
	Real Time Motion	EtherCAT (CoE)	None	RTMoE	RTMoE
	Analog I/O	1 Analog Input $\pm 10V$, 12 bits (11 bits + sign)			
	Digital I/O	2 DI, 2 DO (100 mA), 1 motor brake output (1 A, max 1.3 A)			
	Pulse Train Input	Frequency/Direction 5 V differential, 500 kHz			
	Encoder Feedback	2 x Encoder input and 1 simulated encoder output			
	Supported Encoders	Resolver, Quadrature, AB Servo, SinCos, EnDat (2.1/2.2), SSI, BiSS, Hiperface			
	Safety	2 x Safe Torque Off (STO) via terminal, PLe, SIL3			
Commissioning	Interface	EtherNet over EtherCAT (EoE)	RS485	EtherNet	RS485 / EtherNet
	Commissioning Tool	Connect			
	Motion Programming Tool	Machine Control Studio			
General	Mechanical Attributes	Removable cable screen clamp			
		User replaceable fan(s)			
		Conformal coating			
	Backup	SD Card			
		Electronic motor nameplate parameter storage (HIPERFACE, Endat 2.2)			
	Braking	Braking resistor: external / drive mountable			
		Braking chopper: integrated			
	Multi-axis	Busbars for common DC bus and earthing			
Quick Links for 24 V distribution					
Display	Yes	Optional	Yes	Optional	

RFC-S: Rotor Flux Control for Synchronous (permanent magnet brushless) motors

RFC-A: Rotor Flux Control for Asynchronous (induction) motors

* The stated percentages apply only to three phase continuous current

DIGITAX HD

SPECIFICATION

400 V Three Phase

Frame Size W x D x H mm (in)	Frame Size 01 40 x 174 x 233 (1.57 x 6.85 x 9.17)	Frame Size 02 40 x 174 x 278 (1.57 x 6.85 x 10.94)	Frame Size 03 40 x 174 x 328 (1.57 x 6.85 x 12.91)			
Line Supply	Single Phase AC 200 V...240 V (± 10%) @ 45...66 Hz					
M75X-...	01200022	01200040	01200065	02200090	02200120	03200160
Output Servo						
Rated Current (A)	1.1	2.2	3.5	5.6	7.5	10.8
Max Peak Current (A)	6.6	12	19.5	27	36	48
Output AC Induction						
Max Continuous Current (A)	1.1	2.2	3.5	5.6	7.5	10.8
Open Loop Peak Current (A)	3.3	6	9.8	13.5	18	24
Closed Loop Peak Current (A)	6.6	12	19.5	27	36	48
Motor Power at 230 V (kW)	0.18	0.37	0.75	1.1	1.5	2.2
Motor Power at 230 V (hp)	0.25	0.5	1.0	1.5	2.0	3.0
Overload						
Closed-loop Overload	Maximum closed loop peak current for 0.25 s					
Open-loop Overload	Maximum open loop peak current for 8 s					

200 V Three Phase

Frame Size W x D x H mm (in)	Frame Size 01 40 x 174 x 233 (1.57 x 6.85 x 9.17)			Frame Size 02 40 x 174 x 278 (1.57 x 6.85 x 10.94)			Frame Size 03 40 x 174 x 328 (1.57 x 6.85 x 12.91)	
Line supply	Three Phase AC 200 V...240 V (± 10%) @ 45...66 Hz							
	M75X-...	01200022	01200040	01200065	02200090	02200120	03200160	
Input								
Max Power (kW)	4			5.3			10*	
Output Servo								
Rated Current (A)	2.2	4	6.5	9	12	16		
Max Peak Current (A)	6.6	12	19.5	27	36	48		
Output AC Induction								
Max Continuous Current (A)	2.2	4	6.5	9	12	16		
Open Loop Peak Current (A)	3.3	6	9.8	13.5	18	24		
Closed Loop Peak Current (A)	6.6	12	19.5	27	36	48		
Motor Power at 230 V (kW)	0.37	0.75	1.1	2.2	2.2	4.0		
Motor Power at 230 V (hp)	0.5	1.0	1.5	2.0	3.0	5.0		
Overload								
Closed-loop Overload	300 % for 0.25 s or 200 % for 4 s							
Open-loop Overload	150 % for 8 s							

400 V Three Phase

Frame Size W x D x H mm (in)	Frame Size 01 40 x 174 x 233 (1.57 x 6.85 x 9.17)			Frame Size 02 40 x 174 x 278 (1.57 x 6.85 x 10.94)			Frame Size 03 40 x 174 x 328 (1.57 x 6.85 x 12.91)			
Line supply	Three Phase AC 380 V...480 V (± 10%) @ 45...66 Hz									
	M75X-...	01400015	01400030	01400042	02400060	02400080	02400105	03400135	03400160	
Input										
Max Power (kW)	6.5			8.7			10/13*			
Output Servo										
Rated Current (A)	1.5	3	4.2	6	8	10.5	13.5	16		
Max Peak Current (A)	4.5	9	12.6	18	24	31.5	40.5	48		
Output AC Induction										
Max Continuous Current (A)	1.5	3	4.2	6	8	10.5	13.5	16		
Open Loop Peak Current (A)	2.3	4.5	6.3	9	12	15.8	20.3	24		
Closed Loop Peak Current (A)	4.5	9	12.6	18	24	31.5	40.5	48		
Motor Power at 400 V (kW)	0.37	0.75	1.5	2.2	3.0	4.0	5.5	5.5		
Motor Power at 400 V (hp)	0.75	1.5	2.0	3.0	5.0	5.0	7.5	10.0		
Overload										
Closed-loop Overload	300 % for 0.25 s or 200 % for 4 s									
Open-loop Overload	150 % for 8 s									

ENVIRONMENT SAFETY AND ELECTRICAL CONFORMANCE

Environment

- IP rating: M75x drives are rated to IP20 (dry, non-conductive contamination)
- UL open class
- Ambient temperature -20 °C (-4 °F) to 40 °C (104 °F) as standard. Up to 55 °C (131 °F) with derating
- Humidity 95 % maximum (non-condensing) at 40 °C (104 °F)
- 1,000 m to 3,000 m (3,300 ft to 9,900 ft) above sea level: de-rate the maximum output current from the specified figure by 1% per 100 m (330 ft) above 1,000 m (3,300 ft)
- Storage temperature -40 °C (-40 °F) to 70 °C (158 °F)
- Mechanical Shock Tested in accordance with IEC 60068-2-27
- Random Vibration: Tested in accordance with IEC 60068-2-64

Safety

- Safe Torque Off independently assessed by TÜV to IEC 61800-5-2
- SIL 3 and EN ISO 13849-1 PLe
- UL 61800-5-1 (Electrical Safety)

Electrical conformance

- Electromagnetic Immunity complies with EN 61800-3 and EN 61000-6-2
- With onboard EMC filters, complies with EN 61800-3 (2nd environment)
- EN 61000-6-3 and EN 61000-6-4 with optional EMC filter
- IEC 60146-1-1 supply conditions
- IEC 61800-5-1 (Electrical Safety)
- IEC 61131-2 I/O



Dimensions

Frame 1

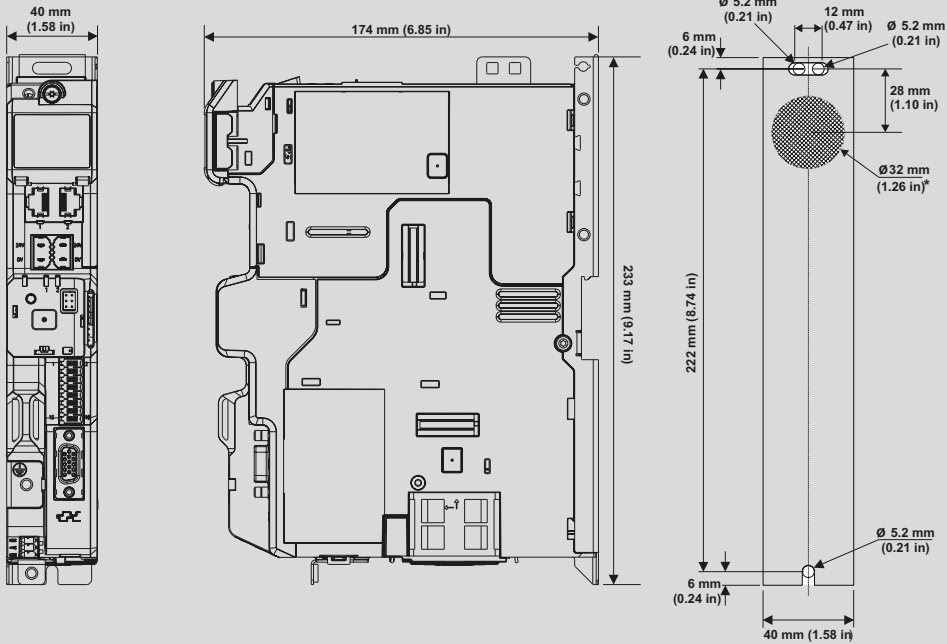

Frame 2

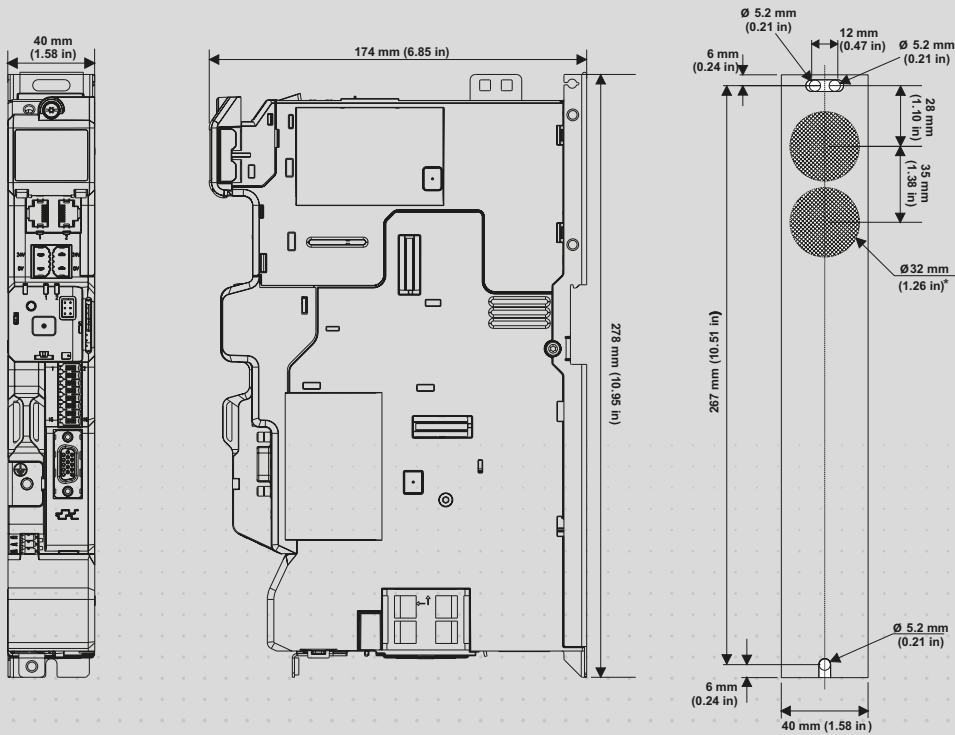

Frame 3

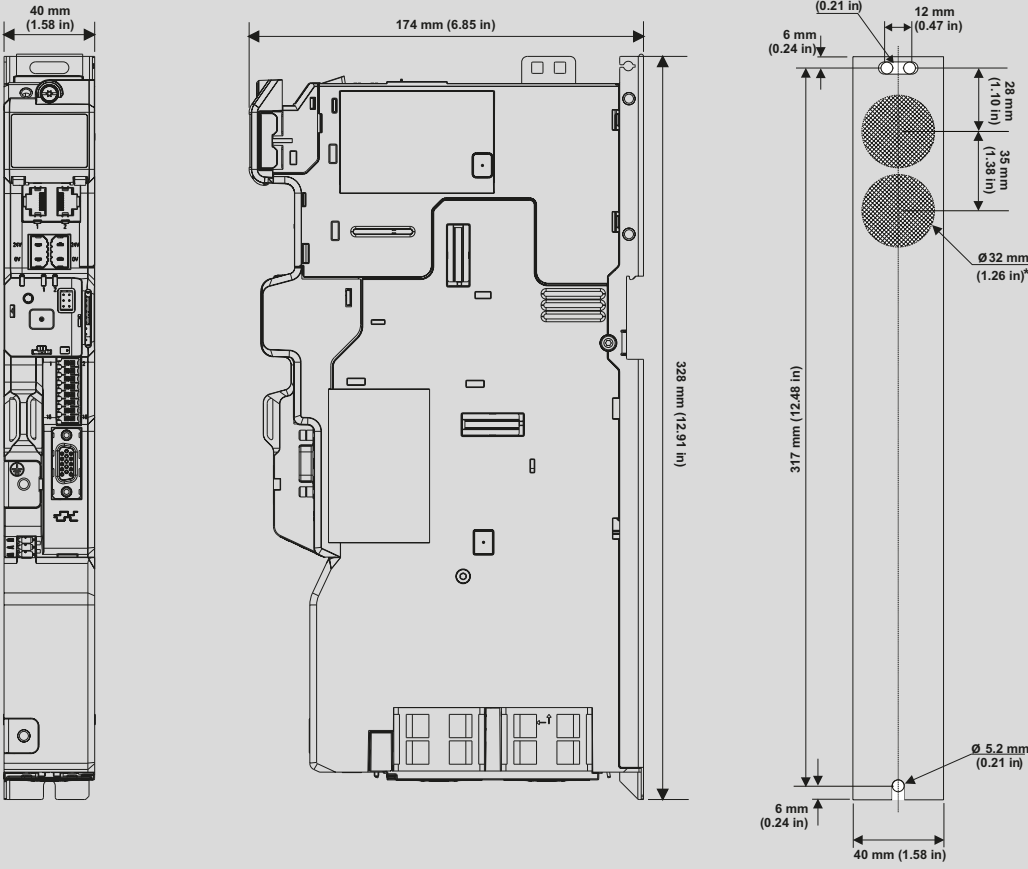

- Notes:**
- Additional space above and below the drive may be required for cable routing.
 - Option module frame adds 22mm width.
 - Alternative screw mounting options available. Please refer to the Installation Guide.

Unimotor HD Servo Series

Frame size 055

Motor frame size (mm)	055ED			055UD			
Voltage (Vrms)	200-240			380-480w			
Frame length	A	B	C	A	B	C	
Continuous stall torque (Nm)	0.69	1.13	1.58	0.69	1.13	1.58	
Continuous stall torque (lb-in)	6.11	10.0	13.98	6.11	10.0	13.98	
Peak torque (Nm)	2.07	3.4	4.75	2.07	3.4	4.75	
Peak torque (lb-in)	18.32	30.09	42.04	18.32	30.09	42.04	
Standard inertia (kgcm ²)	0.14	0.25	0.36	0.14	0.25	0.36	
Standard inertia (lb-in-sec ²)	0.00012	0.00022	0.00032	0.00012	0.00022	0.00032	
Winding thermal time constant (sec)	34	38	42	34	38	42	
Motor weight unbraked (kg)	2.0	2.6	3.2	1.96	2.56	3.16	
Motor weight unbraked (lb)	4.41	5.73	7.05	4.32	5.64	6.97	
Motor weight braked (kg)	2.6	3.2	3.8	2.56	3.16	3.76	
Motor weight braked (lb)	5.73	7.05	8.38	5.64	6.97	8.29	
Number of poles	8	8	8	8	8	8	
Speed 3000 (rpm)	Kt (Nm/A) =	0.74	0.87	0.91	0.74	1.49	1.65
	Kt (lb-in/A) =	6.55	7.7	8.05	6.55	13.19	14.6
	Ke (V/krpm) =	45	52.5	55	45	90	100
Rated torque (Nm)	0.67	1.01	1.42	0.67	1.01	1.42	
Rated torque (lb-in)	5.93	8.94	12.57	5.93	8.94	12.57	
Stall current (A)	0.74	1.22	1.7	0.93	0.76	0.96	
Rated power (kW)	0.21	0.32	0.45	0.21	0.32	0.45	
R (ph-ph) (Ohms)	28	14.12	9.53	28	45	31	
L (ph-ph) (mH)	50	32	23	50	100	75	
Recommended power conn' size	1	1	1	1	1	1	
Speed 6000 (rpm)	Kt (Nm/A) =	0.45	0.43	0.48	0.74	0.79	0.83
	Kt (lb-in/A) =	3.98	3.81	4.25	6.55	6.99	7.35
	Ke (V/krpm) =	27	26	29	45	47.5	50
Rated torque (Nm)	0.68	0.9	1.2	0.68	0.9	1.2	
Rated torque (lb-in)	6.02	7.97	10.62	6.02	7.97	10.62	
Stall current (A)	1.61	2.74	3.44	0.93	1.43	1.91	
Rated power (kW)	0.43	0.57	0.75	0.43	0.57	0.75	
R (ph-ph) (Ohms)	8.5	3.55	2.38	28	10.7	7.8	
L (ph-ph) (mH)	16	8.2	6.3	50	25	20	
Recommended power conn' size	1	1	1	1	1	1	

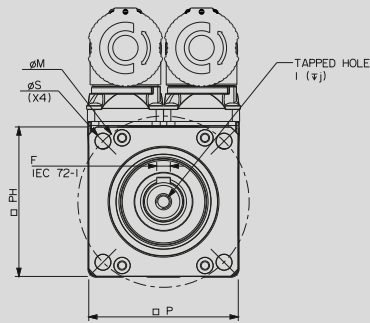

- $\Delta t = 100^{\circ}\text{C}$ winding 40°C (104°F) maximum ambient. All data subject to +/-10% tolerance
- Stall torque, rated torque and power relate to maximum continuous operation tested in a 20°C (68°F) ambient at **8 kHz drive switching frequency**
- All other figures relate to a 20°C (68°F) motor temperature.
- Maximum intermittent winding temperature is 140°C (284°F)

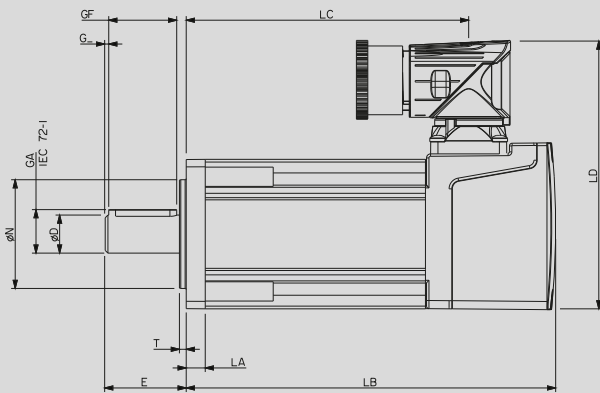

Motor dimensions - Drawing number: GM496400

	Feedback AR, CR, EM, FM				Flange thickness	Register length	Register diameter	Overall height	Flange square	Fixing hole diameter	Fixing hole PCD	Motor housing	Mounting bolts
	Unbraked length		Braked length										
	A	B	A	B									
mm	055A	118.0	90.0	158.0	7.0	2.5	40.0	99.0	55.0	5.8	63.0	55.0	M5
	055B	142.0	114.0	182.0									
	055C	166.0	138.0	206.0									
in	055A	4.65	3.54	6.22	0.28	0.10	1.57	3.90	2.17	0.23	2.48	2.17	
	055B	5.59	4.49	7.17									
	055C	6.54	5.43	8.11									

Shaft dimensions

	Shaft diameter	Shaft length	Key height	Key length	Key to shaft end	Key width	Tapped hole thread size	Tapped hole depth	
	C (j6)	D	E	F	G	H (h9)	I	J	
mm	9.0 Opt	9	20	10.2	15	1	3.0	M4 x 10	10
	11.0 Std	11	23	12.5	15	1.5	4.0	M4 x 10	10
	14.0 Std	14	30.0	16.0	25.0	1.5	5.0	M5x12.5	12.5
in	9.0 Opt	0.354	0.787	0.402	0.591	0.039	0.118	M4 x 10	0.394
	11.0 Std	0.433	0.906	0.492	0.591	0.059	0.157	M4 x 10	0.394
	14.0 Std	0.551	1.181	0.630	0.984	0.059	0.197	M5 x 12.5	0.492

Frame size 067

Motor frame size (mm)	067ED			067UD		
Voltage (Vrms)	200-240			380-480w		
Frame length	A	B	C	A	B	C
Continuous stall torque (Nm)	1.42	2.5	3.63	1.42	2.5	3.63
Continuous stall torque (lb-in)	12.57	22.13	32.13	12.57	22.13	32.13
Peak torque (Nm)	4.26	7.5	10.88	4.26	7.5	10.88
Peak torque (lb-in)	37.7	66.38	96.3	37.7	66.38	96.3
Standard inertia (kgcm ²)	0.30	0.53	0.75	0.30	0.53	0.75
Standard inertia (lb-in-sec ²)	0.00027	0.00047	0.00066	0.00027	0.00047	0.00066
Winding thermal time constant (sec)	54	61	65	54	61	65
Motor weight unbraked (kg)	2	2.6	3.2	1.96	2.56	3.16
Motor weight unbraked (lb)	4.41	5.73	7.05	4.32	5.64	6.97
Motor weight braked (kg)	2.6	3.2	3.8	2.56	3.16	3.76
Motor weight braked (lb)	5.73	7.05	8.38	5.64	6.97	8.29
Number of poles	10	10	10	10	10	10
Speed 3000 (rpm)	Kt (Nm/A) =	0.93		0.8		1.6
	Kt (lb-in/A) =	8.23		7.08		14.16
	Ke (V/krpm) =	57		49		98
Rated torque (Nm)	1.37	2.4	3.43	1.37	2.4	3.43
Rated torque (lb-in)	12.13	21.24	30.36	12.13	21.24	30.36
Stall current (A)	1.53	2.69	3.9	1.78	1.56	2.27
Rated power (kW)	0.43	0.75	1.08	0.43	0.75	1.08
R (ph-ph) (Ohms)	14.92	4.88	3.33	11.69	15.2	10.7
L (ph-ph) (mH)	45.43	17.4	12.7	35.18	54.2	40.8
Recommended power conn' size	1	1	1	1	1	1
Speed 6000 (rpm)	Kt (Nm/A) =	0.47				0.8
	Kt (lb-in/A) =	4.16				7.08
	Ke (V/krpm) =	28.5				49
Rated torque (Nm)	1.3	2.2		1.3	2.2	3.1
Rated torque (lb-in)	11.51	19.47		11.51	19.47	27.44
Stall current (A)	3.02	5.32		1.78	3.12	4.53
Rated power (kW)	0.82	1.38		0.82	1.38	1.95
R (ph-ph) (Ohms)	3.86	1.22		11.69	3.79	2.68
L (ph-ph) (mH)	11.06	4.35		35.18	13.6	10.2
Recommended power conn' size	1	1		1	1	1

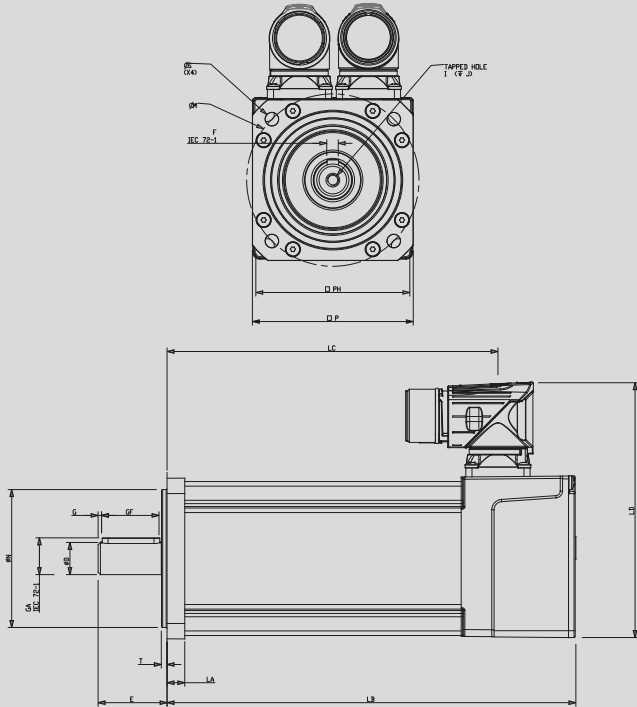

- $\Delta t = 100^{\circ}\text{C}$ winding 40°C (104°F) maximum ambient. All data subject to $\pm 10\%$ tolerance
- Stall torque, rated torque and power relate to maximum continuous operation tested in a 20°C (68°F) ambient at **8 kHz drive switching frequency**
- All other figures relate to a 20°C (68°F) motor temperature
- Maximum intermittent winding temperature is 140°C (284°F)

Motor dimensions - Drawing number: IM/0694/GA

	Feedback AR, CR, EM, FM				Flange thickness LA (± 0.5)	Register length T (± 0.1)	Register diameter N (j6)	Overall height LD (± 0.3)	Flange square P (± 0.3)	Fixing hole diameter S (H14)	Fixing hole PCD M (± 0.5)	Motor housing PH (± 0.5)	Mounting bolts M5
	Unbraked length		Braked length										
	LB (± 0.9)	LC (± 1.0)	LB (± 0.9)	LC (± 1.0)									
mm	067A	142.9	109.0	177.9	144.0								
	067B	172.9	139.0	207.9	174.0	7.7	2.5	60.0	111.5	70.0	5.8	75.0	67.00
	067C	202.9	169.0	237.9	204.0								
in	067A	5.626	4.291	7.004	5.669								
	067B	6.807	5.472	8.185	6.850	0.303	0.098	2.362	4.390	2.756	0.228	2.953	2.638
	067C	7.988	6.654	9.366	8.031								

Shaft dimensions

	Shaft diameter D (j6)	Shaft length E	Key height GA	Key length GF	Key to shaft end G	Key width F (h9)	Tapped hole thread size I	Tapped hole depth J (± 1)
in	0.551	1.181	0.630	.984	0.059	0.197		0.531

Frame size 089

Motor frame size (mm)	089ED			089UD		
Voltage (Vrms)	200-240			380-480w		
Frame length	A	B	C	A	B	C
Continuous stall torque (Nm)	3.1	5.34	7.76	3.1	5.34	7.76
Continuous stall torque (lb-in)	27.44	47.26	68.68	27.44	47.26	68.68
Peak torque (Nm)	9.31	16.01	23.28	9.31	16.01	23.28
Peak torque (lb-in)	82.4	141.7	206.05	82.4	141.7	206.05
Standard inertia (kgcm ²)	0.87	1.61	2.34	0.87	1.61	2.34
Standard inertia (lb-in-sec ²)	0.00077	0.00142	0.00207	0.00077	0.00142	0.00207
Winding thermal time constant (sec)	85	93	98	85	93	98
Motor weight unbraked (kg)	3.18	4.28	5.38	3.18	4.28	5.38
Motor weight unbraked (lb)	7.01	9.44	11.86	7.01	9.44	11.86
Motor weight braked (kg)	3.18	4.28	5.38	3.18	4.28	5.38
Motor weight braked (lb)	9.44	11.86	14.29	9.44	11.86	14.29
Number of poles	10	10	10	10	10	10
Speed 3000 (rpm)	Kt (Nm/A) =		0.93	Kt (Nm/A) =		1.6
	Kt (lb-in/A) =		8.23	Kt (lb-in/A) =		14.16
	Ke (V/krpm) =		57	Ke (V/krpm) =		98
Rated torque (Nm)	2.91	4.7	6.69	2.91	4.7	6.69
Rated torque (lb-in)	25.76	41.6	59.21	25.76	41.6	59.21
Stall current (A)	3.34	5.74	8.34	1.94	3.33	4.85
Rated power (kW)	0.91	1.48	2.1	0.91	1.48	2.1
R (ph-ph) (Ohms)	3.28	1.57	0.89	10.1	5.05	2.68
L (ph-ph) (mH)	21.55	11.84	7.09	65.17	38.36	21.72
Recommended power conn' size	1	1	1	1	1	1
Speed 4000 (rpm)	Kt (Nm/A) =		0.7	Kt (Nm/A) =		1.2
	Kt (lb-in/A) =		6.20	Kt (lb-in/A) =		10.62
	Ke (V/krpm) =		42.75	Ke (V/krpm) =		73.5
Rated torque (Nm)	2.9	4.55	6.35	2.9	4.55	6.35
Rated torque (lb-in)	25.67	40.27	56.2	25.67	40.27	56.2
Stall current (A)	4.43	7.62	11.09	2.59	4.45	6.47
Rated power (kW)	1.21	1.91	2.66	1.21	1.91	2.66
R (ph-ph) (Ohms)	2.04	0.79	0.54	6.16	2.47	1.75
L (ph-ph) (mH)	13.2	5.97	4.38	39.78	18.8	14.03
Recommended power conn' size	1	1	1	1	1	1
Speed 6000 (rpm)	Kt (Nm/A) =		0.47	Kt (Nm/A) =		0.8
	Kt (lb-in/A) =		4.16	Kt (lb-in/A) =		7.08
	Ke (V/krpm) =		28.5	Ke (V/krpm) =		49
Rated torque (Nm)	2.65	3.8	5	2.65	3.8	5
Rated torque (lb-in)	23.45	33.63	44.25	23.45	33.63	44.25
Stall current (A)	6.6	11.35	16.51	3.88	6.67	9.7
Rated power (kW)	1.67	2.39	3.14	1.67	2.39	3.14
R (ph-ph) (Ohms)	0.98	0.39	0.23	2.52	1.27	0.83
L (ph-ph) (mH)	6.24	2.96	1.89	16.29	9.59	6.66
Recommended power conn' size	1	1	1	1	1	1

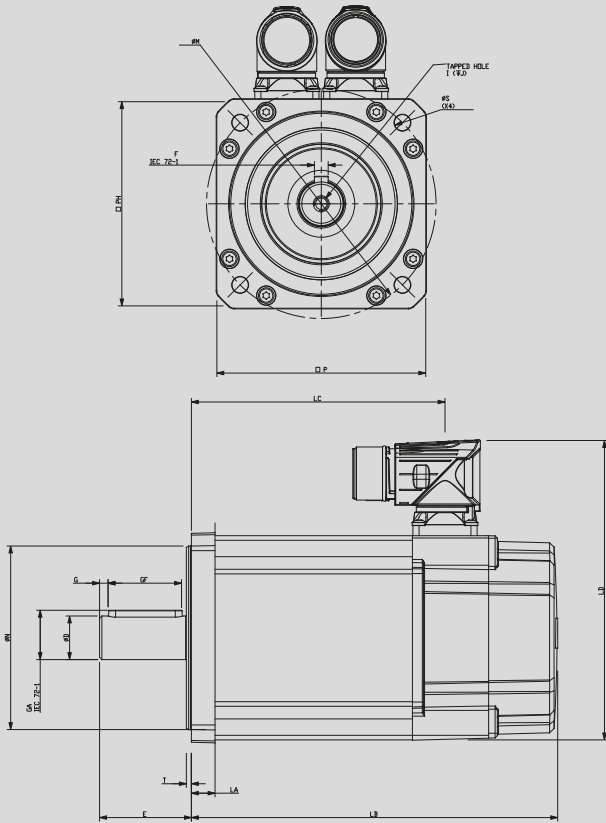

- $\Delta t = 100^{\circ}\text{C}$ winding 40°C (104°F) maximum ambient. All data subject to $\pm 10\%$ tolerance
- Stall torque, rated torque and power relate to maximum continuous operation tested in a 20°C (68°F) ambient at **8 kHz drive switching frequency**
- All other figures relate to a 20°C (68°F) motor temperature
- Maximum intermittent winding temperature is 140°C (284°F)

	Feedback EB, FB, CA, SA, RA		Feedback AE		
	Unbraked length	Braked length	Unbraked length	Braked length	
	LB (± 0.9)	LB (± 0.9)	LB (± 0.9)	LB (± 0.9)	
mm	089A	160.8	200.9	137.8	177.9
	089B	190.8	230.9	167.8	207.9
	089C	220.8	260.9	197.8	237.9
in	089A	6.331	7.909	5.425	7.004
	089B	7.512	9.091	6.606	8.185
	089C	8.693	10.272	7.787	9.366

Motor dimensions - Drawing number: IM/0688/GA

	Feedback EC, FC, LC, NC				Flange thickness	Register length	Register diameter	Overall height	Flange square	Fixing hole diameter	Fixing hole PCD	Motor housing	Mounting bolts
	Unbraked length		Braked length										
	LB (± 0.9)	LC (± 1.0)	LB (± 0.9)	LC (± 1.0)									
mm	089A	147.8	110.5	187.9	150.6	10.3	2.2	80.0	130.5	91.0	7.00	100.0	89.0
	089B	177.8	140.5	217.9	180.6								
	089C	207.8	170.5	247.9	210.6								
in	089A	5.819	4.350	7.398	5.929	0.406	0.087	3.150	5.138	3.583	0.276	3.937	3.504
	089B	7.000	5.531	8.579	7.110								
	089C	8.181	6.713	9.760	8.291								

Shaft dimensions

	Shaft diameter	Shaft length	Key height	Key length	Key to shaft end	Key width	Tapped hole thread size	Tapped hole depth
	D ($j6$)	E	GA	GF	G	F ($h9$)	I	J (± 1)
mm	19.0	40.0	21.5	32.0	3.7	6.0	M6 x 1.0	17.0
in	19.0 (Std)	0.551	1.181	0.630	.0984	0.197		0.669

Frame size 115

Motor frame size (mm)	115ED			115UD		
Voltage (Vrms)	200-240			380-480w		
Frame length	B	C	D	B	C	D
Continuous stall torque (Nm)	10	14.31	18.42	10	14.31	18.42
Continuous stall torque (lb-in)	88.51	126.65	163.03	88.51	126.65	163.03
Peak torque (Nm)	29.99	42.92	55.27	29.99	42.92	55.27
Peak torque (lb-in)	265.43	379.87	489.18	265.43	279.87	489.18
Standard inertia (kgcm ²)	4.41	6.39	8.38	4.41	6.39	8.38
Standard inertia (lb-in-sec ²)	0.00390	0.00566	0.00742	0.00390	0.00566	0.00742
Winding thermal time constant (sec)	164	168	175	164	168	175
Motor weight unbraked (kg)	6.95	8.72	10.49	6.95	8.72	10.49
Motor weight unbraked (lb)	15.32	19.22	23.13	15.32	19.22	23.13
Motor weight braked (kg)	8.45	10.22	11.99	8.45	10.22	11.99
Motor weight braked (lb)	18.63	22.53	26.43	18.63	22.53	26.43
Number of poles	10	10	10	10	10	10
Speed 2000 (rpm)	Kt (Nm/A) =	1.4		2.4		
	Kt (lb-in/A) =	12.39		21.24		
	Ke (V/krpm) =	85.5		147		
Rated torque (Nm)	8.43	11.66	15.29	8.43	11.66	15.29
Rated torque (lb-in)	74.61	103.2	135.33	74.61	103.2	135.33
Stall current (A)	7.14	10.22	13.16	4.17	5.96	7.68
Rated power (kW)	1.76	2.39	3.14	1.77	2.44	3.2
R (ph-ph) (Ohms)	1.4	0.77	0.61	4.41	2.41	1.8
L (ph-ph) (mH)	12.84	7.87	6.62	40.6	24.69	19.45
Recommended power conn' size	1	1	1	1	1	1
Speed 3000 (rpm)	Kt (Nm/A) =	0.93		1.6		
	Kt (lb-in/A) =	8.23		14.16		
	Ke (V/krpm) =	57		98		
Rated torque (Nm)	7.55	10.29		7.55	10.29	13.33
Rated torque (lb-in)	66.82	91.07		66.82	91.07	117.98
Stall current (A)	10.75	15.38		6.25	8.94	11.52
Rated power (kW)	2.37	3.23		2.37	3.23	4.19
R (ph-ph) (Ohms)	0.58	0.39		1.83	1.21	0.78
L (ph-ph) (mH)	5.4	4.01		16.93	12.72	8.65
Recommended power conn' size	1	1		1	1	1

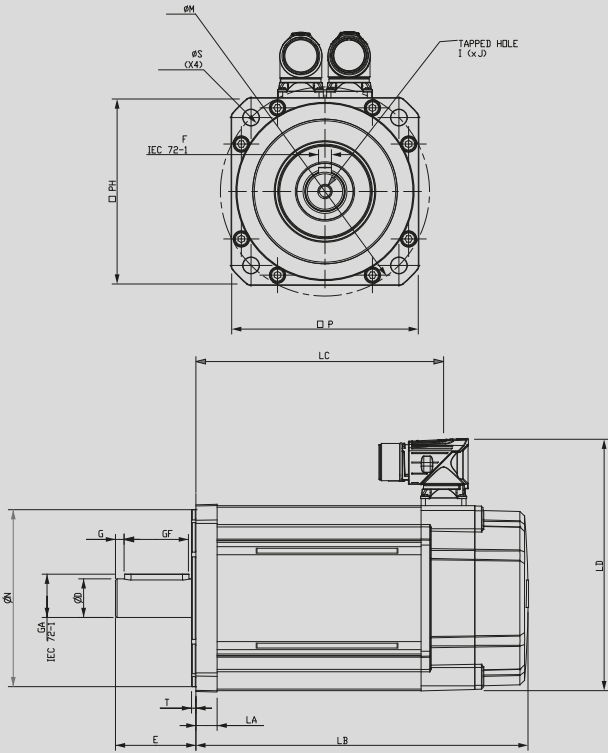

- $\Delta t = 100^{\circ}\text{C}$ winding 40°C (104°F) maximum ambient. All data subject to $\pm 10\%$ tolerance
- Stall torque, rated torque and power relate to maximum continuous operation tested in a 20°C (68°F) ambient at **8 kHz drive switching frequency**
- All other figures relate to a 20°C (68°F) motor temperature.
- Maximum intermittent winding temperature is 140°C (284°F)

	Feedback EB, FB, CA, SA, RA		Feedback AE		
	Unbraked length	Braked length	Unbraked length	Braked length	
	LB (± 0.9)	LB (± 0.9)	LB (± 0.9)	LB (± 0.9)	
mm	115B	206.8	243.9	183.8	220.9
	115C	236.8	273.9	213.8	250.9
	115D	266.8	303.9	243.8	280.9
in	115B	8.142	9.602	7.236	8.697
	115C	9.323	10.783	8.417	9.878
	115D	10.504	11.965	9.598	11.059

Motor dimensions - Drawing number: IM/0689/GA

	Feedback EC, FC, LC, NC				Flange thickness	Register length	Register diameter	Overall height	Flange square	Fixing hole diameter	Fixing hole PCD	Motor housing	Mounting bolts
	Unbraked length		Braked length										
	LB (± 0.9)	LC (± 1.0)	LB (± 0.9)	LC (± 1.0)									
mm	115B	193.8	154.0	230.9	191.1	13.2	2.7	110.0	156.5	116.0	10.00	130.0	115.0
	115C	223.8	184.0	260.9	221.1								
	115D	253.8	214.0	290.9	251.1								
in	115B	7.630	6.063	9.091	7.524	0.520	0.106	4.331	6.161	4.567	0.394	5.118	4.528
	115C	8.811	7.244	10.272	8.705								
	115D	9.992	8.425	11.453	9.886								

Shaft dimensions

	Shaft diameter	Shaft length	Key height	Key length	Key to shaft end	Key width	Tapped hole thread size	Tapped hole depth
	D (j6)	E	GA	GF	G	F (h9)	I	J (± 1)
mm	24.0	50.0	27.0	40.0	5.3	8.0	M8 x 1.25	20.0
in	24.0 (Std)	0.945	1.969	1.063	1.575	0.209		0.315

Frame size 142

Motor frame size (mm)	142ED			142UD		
Voltage (Vrms)	200-240			380-480w		
Frame length	C	D	E	C	D	E
Continuous stall torque (Nm)	22.75	28.67	34.58	22.75	28.67	34.58
Continuous stall torque (lb-in)	201.35	253.75	306.06	201.35	253.75	306.06
Peak torque (Nm)	68.25	86	103.74	68.25	86	103.74
Peak torque (lb-in)	604.06	761.16	918.18	604.06	761.16	918.18
Standard inertia (kgcm ²)	17	22.1	27.2	17	22.1	27.2
Standard inertia (lb-in-sec ²)	0.01505	0.01956	0.02407	0.01505	0.01956	0.02407
Winding thermal time constant (sec)	245	251	256	245	251	256
Motor weight unbraked (kg)	12.74	15.39	18.04	12.74	15.39	18.04
Motor weight unbraked (lb)	28.09	33.93	39.77	28.09	33.93	39.77
Motor weight braked (kg)	14.82	17.47	20.12	14.82	17.44	20.12
Motor weight braked (lb)	32.67	68.51	44.36	32.67	38.45	44.36
Number of poles	10	10	10	10	10	10
Speed 1000 (rpm)	Kt (Nm/A) =		2.8			
	Kt (lb-in/A) =		24.78			
	Ke (V/krpm) =		171			
Rated torque (Nm)	21.2	26.39	31.4			
Rated torque (lb-in)	187.64	233.57	277.91			
Stall current (A)	8.1	10.19	12.38			
Rated power (kW)	2.22	2.77	3.29			
R (ph-ph) (Ohms)	1.36	0.94	0.72			
L (ph-ph) (mH)	21.34	15.17	12.3			
Recommended power conn' size	1	1	1			
Speed 2000 (rpm)	Kt (Nm/A) =		1.4	2.4		
	Kt (lb-in/A) =		12.39	21.24		
	Ke (V/krpm) =		85.5	147		
Rated torque (Nm)	19.47	23.39	26.94	19.47	23.39	26.94
Rated torque (lb-in)	172.32	207.02	238.44	172.32	207.02	238.44
Stall current (A)	16.25	20.48	24.7	9.48	11.94	14.41
Rated power (kW)	4.08	4.9	5.64	4.08	4.9	5.64
R (ph-ph) (Ohms)	0.34	0.24	0.18	0.79	0.62	0.49
L (ph-ph) (mH)	5.33	3.79	3.07	12.15	9.66	8.34
Recommended power conn' size	1.5	1.5	1.5	1	1	1
Speed 3000 (rpm)	Kt (Nm/A) =		0.93	1.6		
	Kt (lb-in/A) =		8.23	14.16		
	Ke (V/krpm) =		57	98		
Rated torque (Nm)	16.74	19.02		16.77	19.02	20.93
Rated torque (lb-in)	148.16	168.34		148.43	168.34	185.25
Stall current (A)	24.46	30.82		14.22	17.92	21.61
Rated power (kW)	5.26	5.97		5.27	5.97	6.58
R (ph-ph) (Ohms)	0.12	0.10		0.34	0.24	0.18
L (ph-ph) (mH)	1.9	1.57		5.33	3.79	3.07
Recommended power conn' size	1.5	1.5		1	1.5	1.5

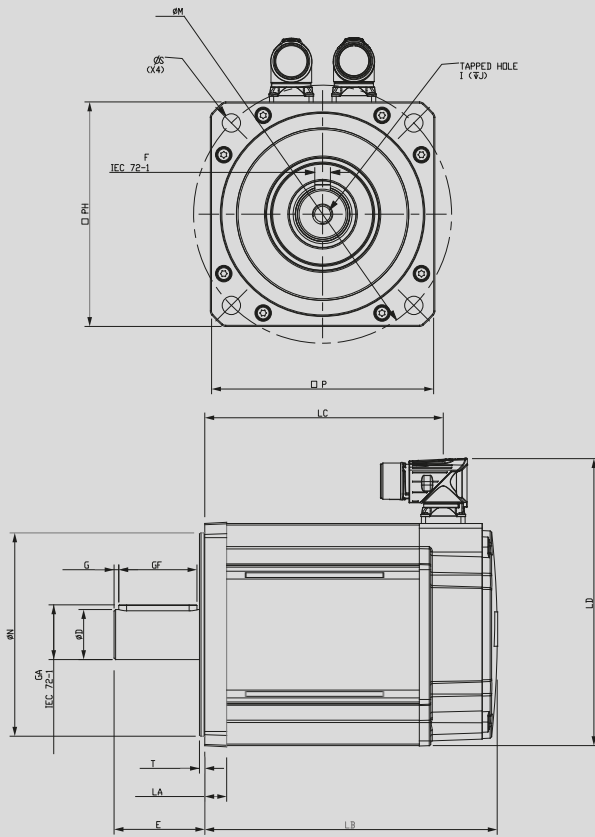

- $\Delta t = 100^{\circ}\text{C}$ winding 40°C (104°F) maximum ambient. All data subject to $\pm 10\%$ tolerance
- Stall torque, rated torque and power relate to maximum continuous operation tested in a 20°C (68°F) ambient at **8 kHz drive switching frequency**
- All other figures relate to a 20°C (68°F) motor temperature.
- Maximum intermittent winding temperature is 140°C (284°F)

Motor dimensions - Drawing number: IM/0709/GA

	Unbraked length		Braked length		Flange thickness	Register length	Register diameter	Overall height	Flange square	Fixing hole diameter	Fixing hole PCD	Motor housing	Mounting bolts
	LB (± 0.9)	LC (± 1.0)	LB (± 0.9)	LC (± 1.0)									
mm	142C	217.0	182.5	282.5	14.0	3.4	130.0	183.5	142.0	12.0	165.0	142.0	M10
	142D	247.0	212.5	312.5				183.5-204.5					
	142E	277.0	242.5	342.5				308.0					
in	142C	8.543	7.185	11.122	0.551	0.134	5.118	7.224	5.591	0.472	6.496	5.591	M10
	142D	9.724	8.366	12.303				7.224-8.051					
	142E	10.906	9.547	13.484				12.126					

Shaft dimensions

	Shaft diameter	Shaft length	Key height	Key length	Key to shaft end	Key width	Tapped hole thread size	Tapped hole depth
	D (j6)	E	GA	GF	G	F (h9)	I	J (± 1)
mm	32.0	58.0	35.0	50.0	3	10.0	M12 x 1.75	29.0
in	32.0 (Std)	2.283	1.378	1.969	0.118	0.394		1.142

Frame size 190

Motor frame size (mm)	190ED			190UD		
Voltage (Vrms)	200-240			380-480w		
Frame length	C	D	F	C	D	F
Continuous stall torque (Nm)	52	62	85	52	62	85
Continuous stall torque (lb-in)	460.24	548.75	752.31	460.24	548.75	752.31
Peak torque (Nm)	156	186	255	156	186	255
Peak torque (lb-in)	1380.72	1646.24	2256.94	1380.72	1646.24	2256.94
Standard inertia (kgcm ²)	54.6	70.9	103.5	54.6	70.9	103.5
Standard inertia (lb-in-sec ²)	0.04832	0.06275	0.09161	0.04832	0.06275	0.09161
Winding thermal time constant (sec)	311	316	324	311	316	324
Motor weight unbraked (kg)	27.74	34.3	47.42	27.74	34.3	47.42
Motor weight unbraked (lb)	61.16	75.62	104.54	61.16	75.62	104.54
Motor weight braked (kg)	31.38	37.94	56.74	31.38	37.94	56.74
Motor weight braked (lb)	69.18	83.64	125.09	69.18	83.64	125.09
Number of poles	10	10	10	10	10	10
	Kt (Nm/A) =		2.8			
Speed 1000 (rpm)	Kt (lb-in/A) =		24.78			
	Ke (V/krpm) =		171			
Rated torque (Nm)	49	56.5	77.5			
Rated torque (lb-in)	433.69	500.07	685.93			
Stall current (A)	18.6	22.1	30.4			
Rated power (kW)	5.13	5.92	8.12			
R (ph-ph) (Ohms)	0.47	0.4	0.23			
L (ph-ph) (mH)	12.3	10.4	6.79			
Recommended power conn' size	1.5	1.5	1.5			
	Kt (Nm/A) =			3.2		
Speed 1500 (rpm)	Kt (lb-in/A) =			28.32		
	Ke (V/krpm) =			196		
Rated torque (Nm)				46.2	52.2	68.5
Rated torque (lb-in)				408.9	462.01	606.28
Stall current (A)				16.3	19.4	26.6
Rated power (kW)				7.26	8.2	10.76
R (ph-ph) (Ohms)				0.57	0.4	0.23
L (ph-ph) (mH)				14.15	10.4	6.79
Recommended power conn' size				1.5	1.5	1.5
	Kt (Nm/A) =		1.4	2.4		
Speed 2000 (rpm)	Kt (lb-in/A) =		12.39	21.24		
	Ke (V/krpm) =		85.5	147		
Rated torque (Nm)	42.5			42.5	45.3	56.0
Rated torque (lb-in)	376.16			376.16	400.94	495.65
Stall current (A)	37.14			21.7	25.8	35.42
Rated power (kW)	8.9			8.9	9.5	11.7
R (ph-ph) (Ohms)	0.12			0.34	0.17	0.14
L (ph-ph) (mH)	3.07			8.2	5.05	4.55
Recommended power conn' size	1.5			1.5	1.5	1.5

a

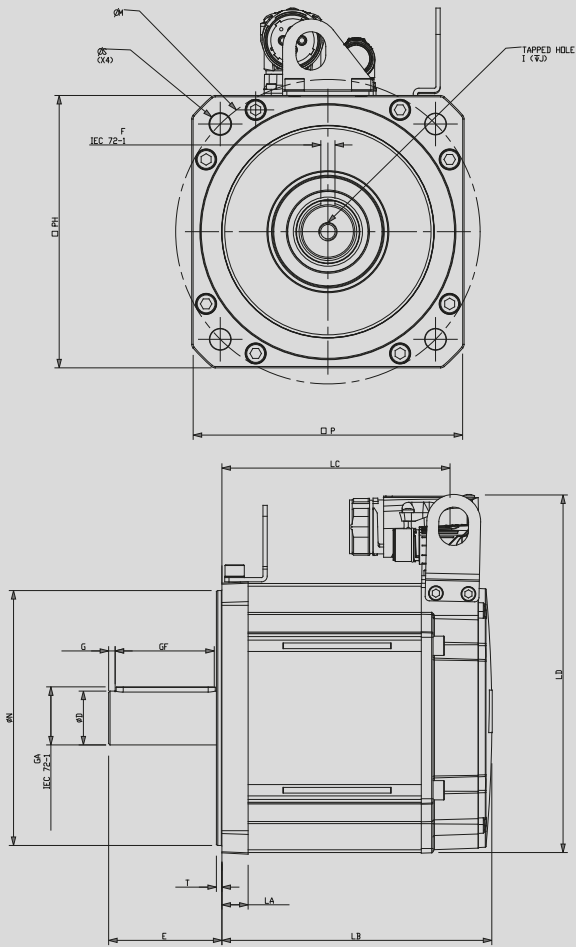

- $\Delta t = 100^{\circ}\text{C}$ winding 40°C (104°F) maximum ambient. All data subject to $\pm 10\%$ tolerance
- Stall torque, rated torque and power relate to maximum continuous operation tested in a 20°C (68°F) ambient at **8 kHz drive switching frequency**
- All other figures relate to a 20°C (68°F) motor temperature.
- Maximum intermittent winding temperature is 140°C (284°F)

Motor dimensions - Drawing number: IM/00710/GA

	Unbraked length		Braked length		Flange thickness	Register length	Register diameter	Overall height	Flange square	Fixing hole diameter	Fixing hole PCD	Motor housing	Mounting bolts
	LB (± 0.9)	LC (± 1.0)	LB (± 0.9)	LC (± 1.0)									
mm	190C	220.6	191.1	319.1	18.5	3.9	180.0	252.5	190.3	14.5	215.0	190.0	M12
	190D	250.6	221.1	349.1									
	190F	310.6	281.1	409.1									
in	190C	8.685	7.524	12.563	0.728	0.154	7.087	9.941	7.492	0.571	8.465	7.480	
	190D	9.866	8.705	13.744									
	190F	12.229	11.067	16.106									

Shaft dimensions

	Shaft diameter	Shaft length	Key height	Key length	Key to shaft end	Key width	Tapped hole thread size	Tapped hole depth
	D (j6)	E	GA	GF	G	F (h9)	I	J (± 1)
mm	38.0	80.0	41.0	70.0	4.6	10.0		29.0
in	38.0 (Std)	3.150	1.614	2.756	0.181	0.394	M12 x 1.75	1.142

DRIVE OBSESSED



Control Techniques has been designing and manufacturing the best variable speed drives in the world since 1973.

Our customers reward our commitment to building drives that outperform the market. They trust us to deliver on time every time with our trademark outstanding service.

More than 45 years later, we're still in pursuit of the best motor control, reliability and energy efficiency you can build into a drive. That's what we promise to deliver, today and always.

1.4K+

Employees

70

Countries

#1 FOR ADVANCED MOTOR AND DRIVE TECHNOLOGY



Nidec Corporation is a global manufacturer of electric motors and drives.

Nidec was set up in 1973. The company made small precision AC motors and had four employees. Today, it's a global corporation that develops, builds and installs cutting-edge drives, motors and control systems in over 70 countries with a workforce of more than 110,000.

You'll find its innovations in thousands of industrial plants, IoT products, home appliances, cars, robotics, mobile phones, haptic devices, medical apparatus and IT equipment all over the world.

109K

Employees

\$14.6B

Group Turnover

70+

Countries

330+

Companies

CONTROL TECHNIQUES IS YOUR GLOBAL DRIVES SPECIALIST.

With operations in over 70 countries, we're open for business wherever you are in the world.

For more information, or to find your local drive centre representatives, visit:

www.controltechniques.com

Connect with us



©2020 Nidec Control Techniques Limited. The information contained in this brochure is for guidance only and does not form part of any contract. The accuracy cannot be guaranteed as Nidec Control Techniques Ltd have an ongoing process of development and reserve the right to change the specification of their products without notice.

Nidec Control Techniques Limited. Registered Office: The Gro, Newtown, Powys SY16 3BE.

Registered in England and Wales. Company Reg. No. 01236886.

P.N. 0778-0502-07 10/20

